

GA - 586SVX

USER'S MANUAL

PCI - ISA SOLUTION

PENTIUM[®] PCI - ISA BUS MAINBOARD

REV.1.1 Fourth Edition

Who need 82430SVX?

1. If you want to get the best performance.
(Because more buffers & Quick DRAM Timing is supported.)
2. If you need a USB ports for C&C application.
(Because 2 USB ports will be ready in the end of Q2/96".)

Why do you need GA-586SVX 82430SVX motherboard?

1. Because it is the best performance motherboard. (See next page) We have compared GA-586SVX with PC Magazine EDITOR choice-system.
2. Just plug a 256KB Pipeline cache module and you can get cache size upto 512KB easily. No jumper setting needed.

Others don't, because they don't have an upgrade cache module. Or they have to change jumper setting to 512KB.
3. No risk for Intel P55CT CPU upgrade because GA-586SVX will auto detect P55CT and support right operation voltage.

Others don't, because they need an EXTRA VRM module or jumper setting for P55CT CPU upgrade.
4. DIP switch setting is supported. You don't have to worry any jumper shunter missed.

Others don't, because they have jumpers on board.

I. PERFORMANCE

Gateway P5-166 XL (P/166) / SAG STF 166(P/166):

These two systems' score are according to PC Magazine February 20, 1996. Page 146-148.

GA-586SVX (P166):

The system tested with 1.2GB hard disk drive, 4 x CD-ROM, and 16MB of EDO RAM. Using the graphics driver provided from Windows95 in 1024 by 768 resolution with 256 colors, small font, and a refresh rate 72Hz. Also we defragmented hard disk before each test for Windows95 manage virtual memory setting.

Hardware Configuration:

- CPU Intel 166 MHz
- RAM 8MB 2pcs. Total 16 MB (Panasonic EUXSR08XX00E)
- Cache size 256 KB Pipeline Burst SRAM (UMC UM61L3232AF-7) 2 pcs.
512 KB Pipeline Burst SRAM (UMC UM61L3232AF-7) 4 pcs.
- DISPLAY Matrox MGA Millennium Power Desk
- STORAGE Quantum Fireball 1280AT
- O.S. Windows 95

	O.S.	Cache size	VGA	WINSTONE96
Gateway P5-166 XL(P/166)	Windows95	256KB	Matrox MGA Impression	75
SAG STF 166(P/166)	Windows95	512KB	Image 128#9	76
GA-586SVX(P/166)	Windows95	256KB	Matrox MGA Millennium Power Desk	79.6
GA-586SVX(P/166)	Windows95	512KB	Matrox MGA Millennium Power Desk	80.6

II. Quick Installation Guide:

Intel CPU	SW1	SW2	SW3	SW4
1. Pentium 75 MHz	OFF	OFF	ON	ON
2. Pentium 90 MHz	OFF	OFF	OFF	ON
3. Pentium 100 MHz	OFF	OFF	OFF	OFF
4. Pentium 120 MHz	ON	OFF	OFF	ON
5. Pentium 133 MHz	ON	OFF	OFF	OFF
6. Pentium 150 MHz/P55C-150MHz	ON	ON	OFF	ON
7. Pentium 166 MHz/P55C-166MHz	ON	ON	OFF	OFF
8. Pentium 180 MHz	OFF	ON	OFF	ON
9. Pentium 200 MHz/P55C-200MHz	OFF	ON	OFF	OFF
10. P54CT-125 MHz	ON	ON	ON	ON
11. P54CT-150 MHz	ON	ON	OFF	ON
12. P54CT-166 MHz	ON	ON	OFF	OFF
13. P54CTB-150 MHz **	ON	ON	OFF	ON
14. P54CTB-166 MHz **	ON	ON	OFF	OFF
15. P54CTB-180 MHz **	OFF	ON	OFF	ON
16. P54CTB-200 MHz **	OFF	ON	OFF	OFF

AMD\Cyrix CPU	SW1	SW2	SW3	SW4
17. AMDK5- 75 MHz-P75	OFF	OFF	ON	ON
18. AMDK5- 90 MHz-P90	OFF	OFF	OFF	ON
19. AMDK5-100 MHz-P100	OFF	OFF	OFF	OFF
20. AMDK5- 75 MHz-P100	OFF	OFF	ON	ON
21. AMDK5- 90 MHz-P120	OFF	OFF	OFF	ON
22. AMDK5-100 MHz-P133	OFF	OFF	OFF	OFF
23. AMDK5-120 MHz-P150	ON	OFF	OFF	ON
24. AMDK5-133 MHz-P166	ON	OFF	OFF	OFF
25. Cyrix 6x86-100 MHz-P120+	ON	OFF	ON	ON
26. Cyrix 6x86-110 MHz-P133+	ON	OFF	ON	OFF
27. Cyrix 6x86-120 MHz-P150+	ON	OFF	OFF	ON
28. Cyrix 6x86-133 MHz-P166+	ON	OFF	OFF	OFF

* Note : If Cyrix 6x86 is being used, please check the CPU Date Code after 605.

* * Note : To support INTEL CPU P54CTB-150MHz/166MHz/180MHz/200MHz,

GA-586SVX is available from PCB Ver.1.51.

1. Pentium 75 MHz

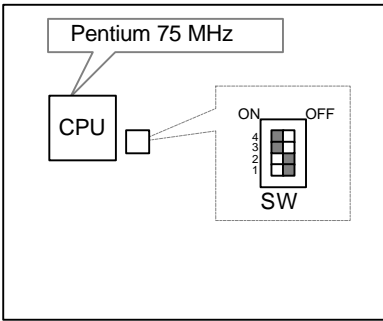

2. Pentium 90 MHz

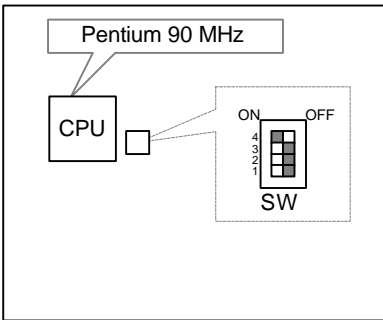

3. Pentium 100 MHz

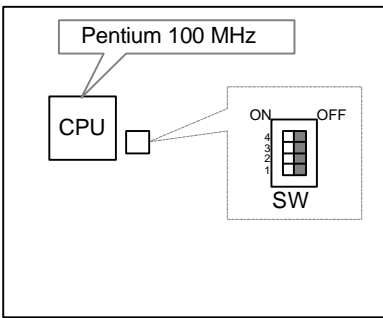

4. Pentium 120 MHz

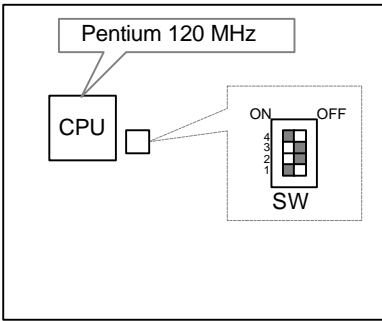

5. Pentium 133 MHz

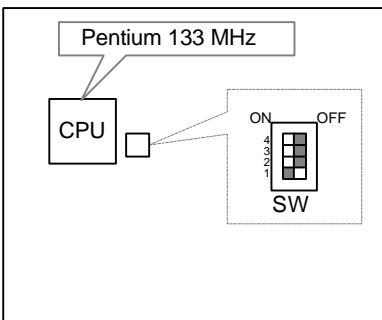

6. Pentium 150 MHz/P55C-150MHz

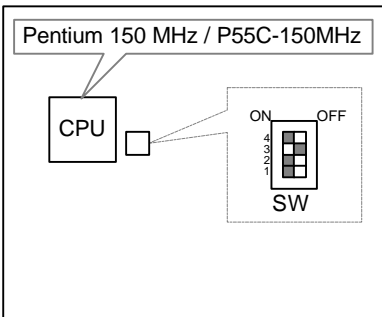

7. Pentium 166 MHz/P55C-

166MHz

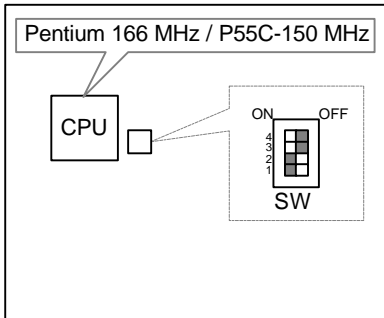

8. Pentium 180 MHz

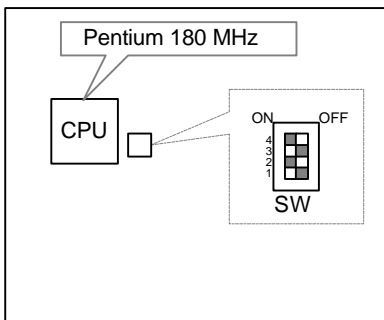

9. Pentium 200 MHz/P55C-200MHz

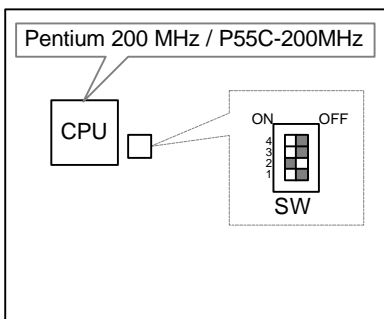

10. P54CT-125 MHz

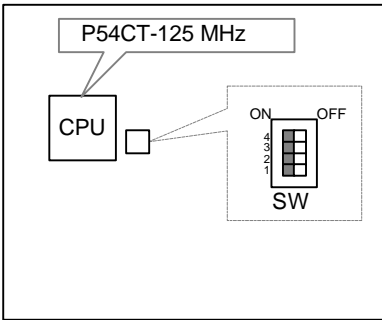

11. P54CT-150 MHz

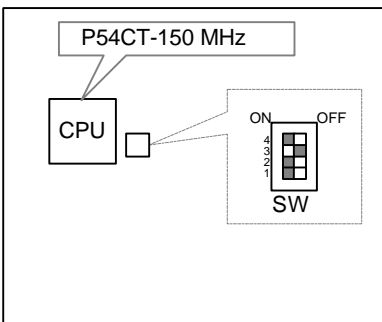

12. P54CT-166 MHz

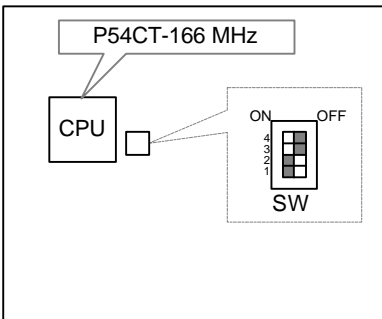

13. P54CTB-150 MHz

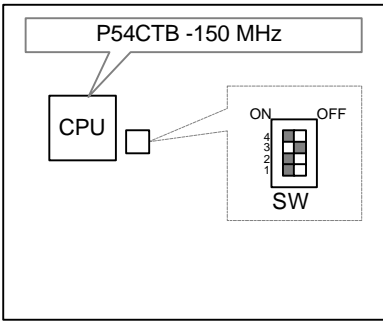

14. P54CTB-166 MHz

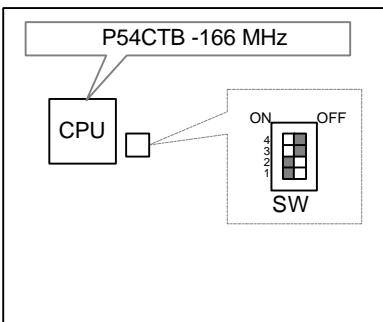

15. P54CTB - 180 MHz

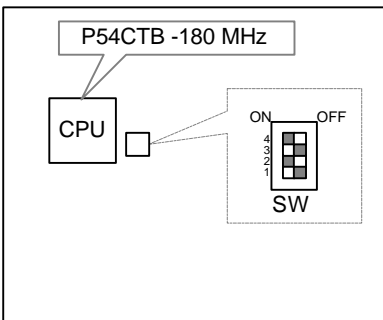

16. P54CTB - 200 MHz

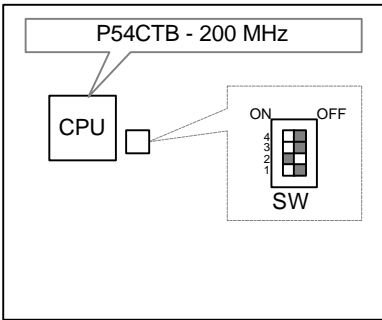

17. AMDK5- 75 MHz-P75

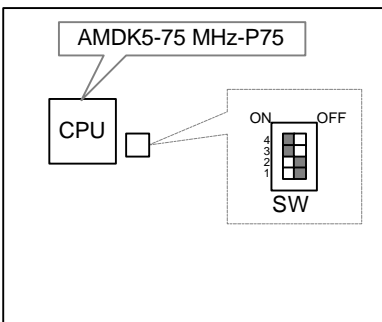

18. AMDK5- 90 MHz-P90

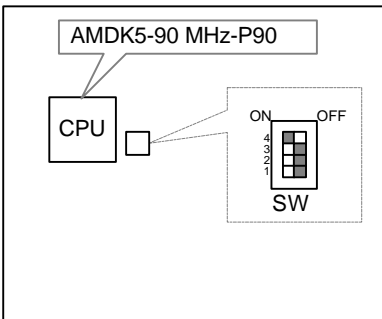

19. AMDK5-100 MHz-P100

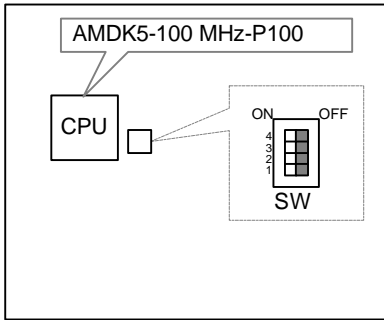

20. AMDK5- 75 MHz-P100

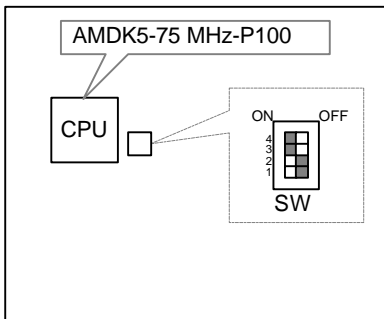

21. AMDK5- 90 MHz-P120

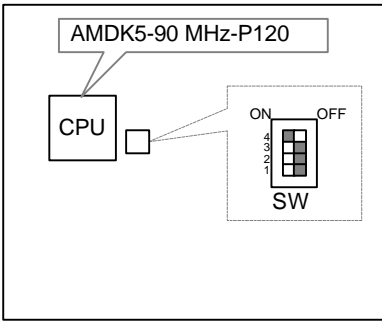

22. AMDK5-100 MHz-P133

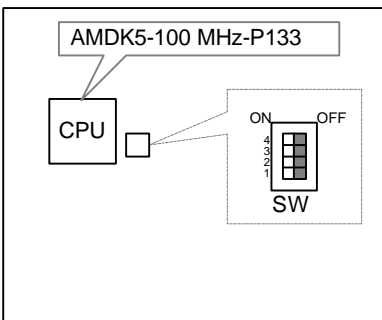

23. AMDK5-120 MHz-P150

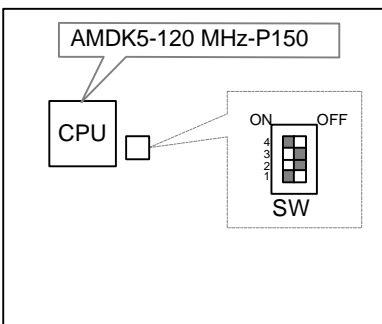

24. AMDK5-133 MHz-P166

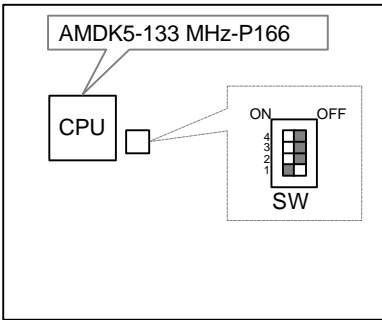

25. Cyrix 6x86-100 MHz-P120+

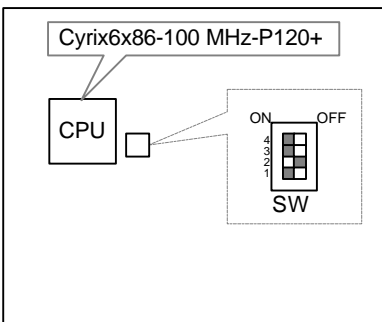

26. Cyrix 6x86-110 MHz-P133+

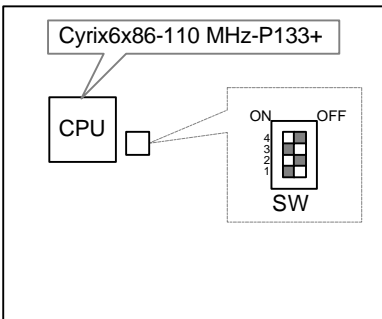

27. Cyrix 6x86-120 MHz-P150+

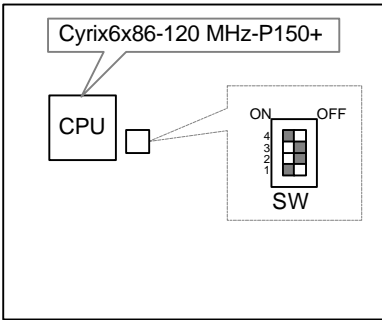

28. Cyrix 6x86-133 MHz-P166+

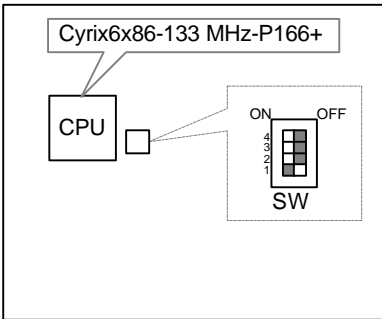

III. SRAM Install

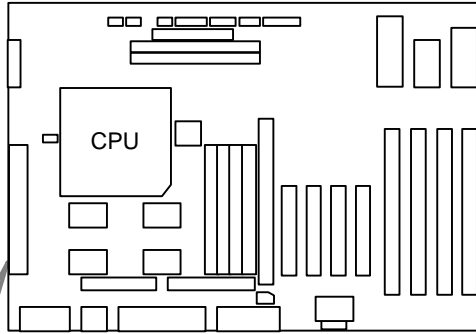

Cache Size 256KB / Cacheable Memory Size 64 MB

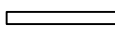
 CN2: Cache Module

 U30,31 : SRAM Pipeline 256KB Onboard (32K*32) 2pcs.

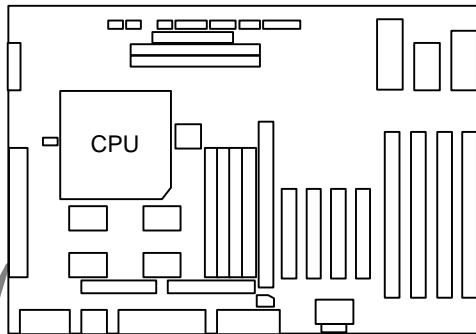

Cache Size 512KB / Cacheable Memory Size 64 MB

 CN2: Cache Module

 U30,31 : SRAM Pipeline 256KB Onboard (32K*32) 2pcs.

IV. Quick Installation Guide of Jumper setting:

GN: Green Function Switch



Close: For system entering Green mode.



Open: Normal operation.

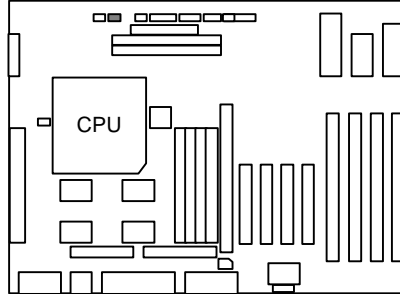

GD: Green Function LED



Pin No.	Function
1	LED anode (+)
2	LED cathode (-)

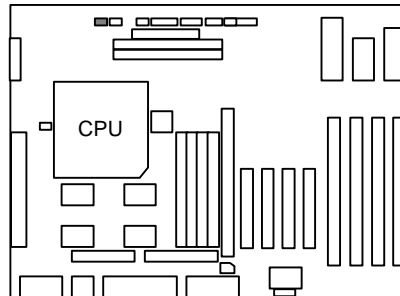

RST: Reset Switch



Close: For hardware reset system.



Open: Normal operation.

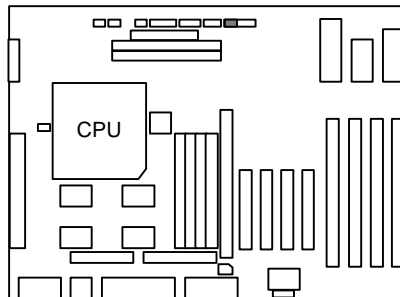

SPK: Speaker Connector

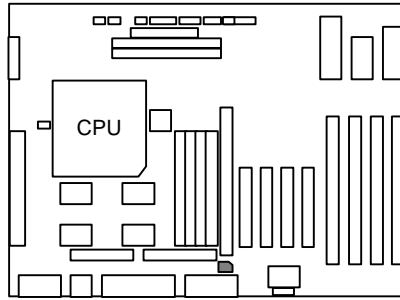
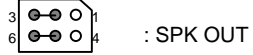
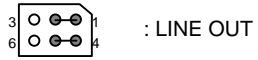

PWR: Power LED and Key-Lock Connector



Pin No.	Function
1	LED anode (+).
2	NC.
3	LED cathode (-).

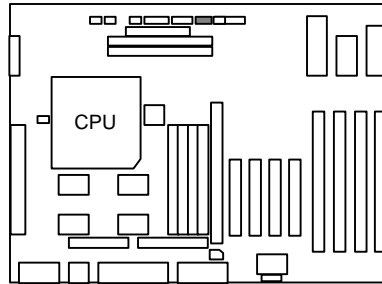

POWER: Power Connector

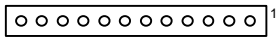

Pin No.	Function
1	Power Good signal.
2,10,11,12	VCC (+5V)
3	+12V
4	-12V
5,6,7,8	GND
9	-5V

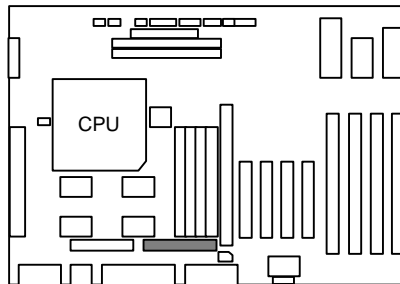

JP8: CPU Cooling Fan Power Connector



Pin No.	Function
1	+12V
2	GND

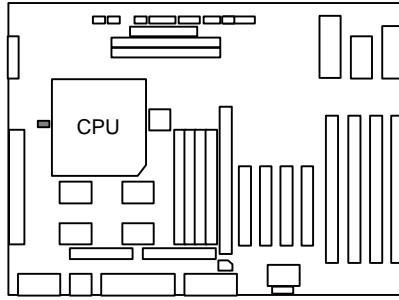

J9: WAVE table Connector

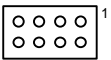

Pin No.	Function
1	EMUR
3	EMUL
2,4,6,7,8	GND
5	NC

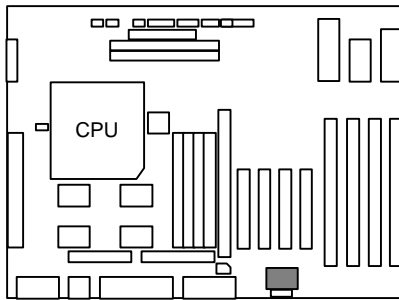

J10: Audio Cable Connector

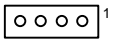

Pin No.	Function
1,3	GND
2	Left
4	Right

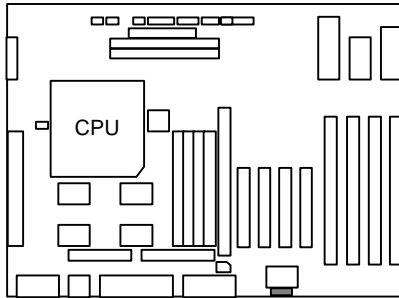

J17,22,24,25,26,31,34: I/O Ports Connector

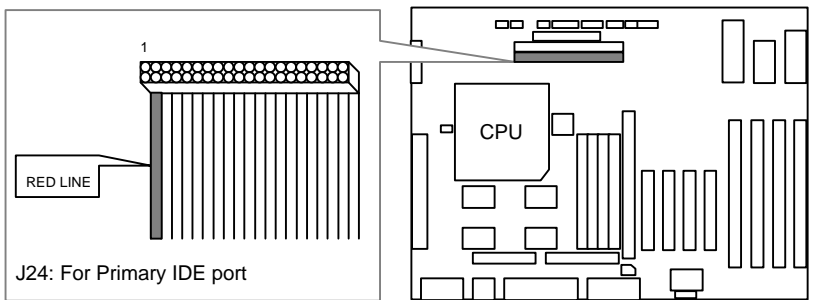
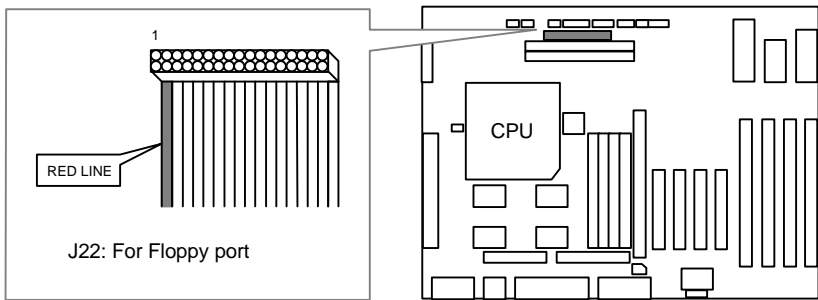
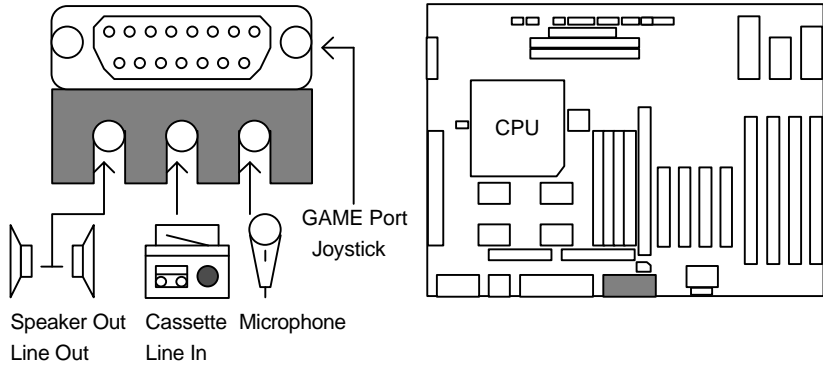

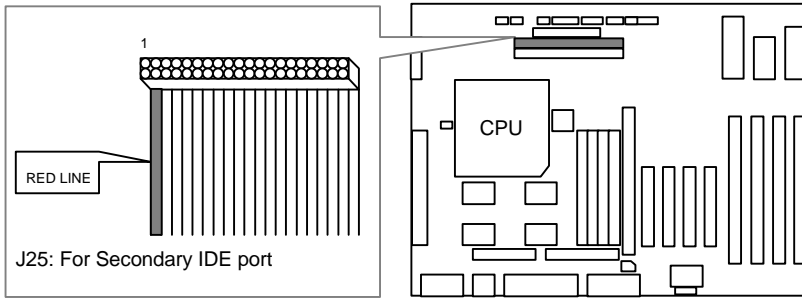

J26: LPT Port

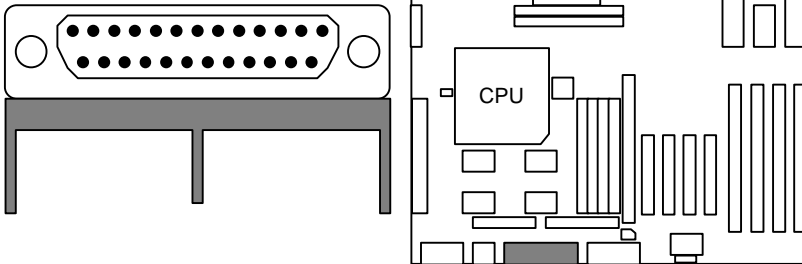

J31: PS/2 Mouse / Keyboard Connector

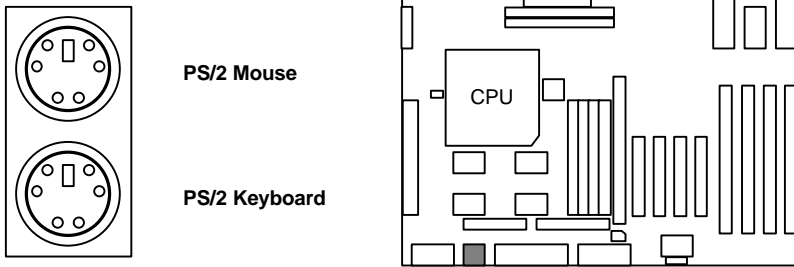

PS/2 Mouse	
Pin No.	Function
1	Key Data
2	NC
3	GND
4	VCC (+5V)
5	Key Clock.
6	NC

PS/2 Keyboard	
Pin No.	Function
1	Key Data
2	NC
3	GND
4	VCC (+5V)
5	Key Clock.
6	NC

J32: ATX Power Connector

Pin No.	Function
1,2,11	NC
3,5,7,13,15,16,17	GND
4,6,19,20	VCC
8	Power good
9	5VSB
10	+12V
12	-12V
14	PSON
18	-5V

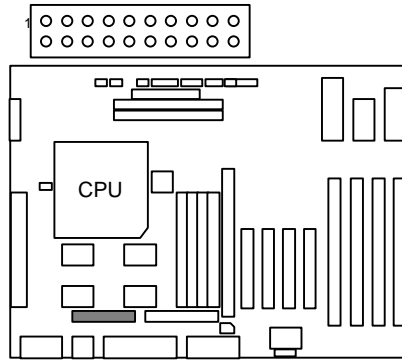

J34: COMA Port / COMB Port

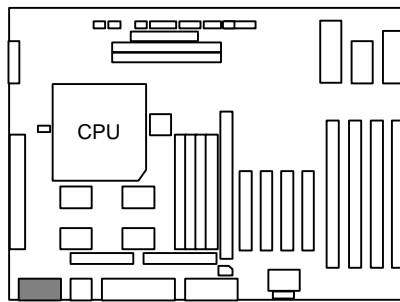
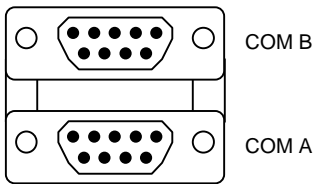

SW3, SW4: For System Speed

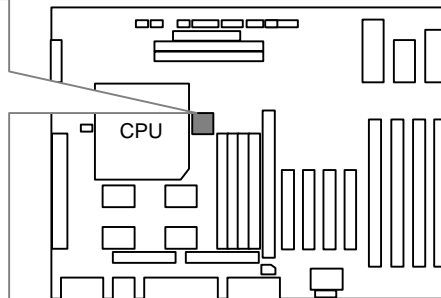
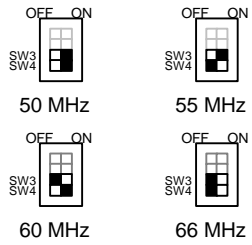

V. Top Performance Test Setting:

Note:Users have to modify the value for each item in chipset features as follow:

Note:60ns EDO-60ns DRAM is necessary for top performance setting.

Chipset features setup

ROM PCI / ISA BIOS
 CHIPSET FEATURES SETUP
 AWARD SOFTWARE, INC.

Auto Configuration	: Disabled	
DRAM RAS# Precharge Time	: 3	
DRAM R/W Leadoff Timing	: 6	
Fast RAS To CAS Delay	: 2	
DRAM Read Burst (EDO/FPM)	: x222/x333	
DRAM Write Burst Timing	: x222	
Fast MA to RAS# Delay CLK	: 1	
Refresh RAS# Assertion	: 4 CLKS	
Turn-Around Insertion	: Disabled	
ISA Clock	: PCI CLK/4	
Pipeline Cache Timing	: Fastest	
System BIOS Cacheable	: Enabled	
Video BIOS Cacheable	: Enabled	
8 Bit I/O Recovery Time	: 1	ESC : Quit ↑ ↓ → ← : Select Item
16 Bit I/O Recovery Time	: 1	F1 : Help PU/PD/+/- : Modify
Memory Hole At 15M-16M	: Disabled	F5 : Old Values (Shift)F2 : Color
Peer Concurrency	: Enabled	F6 : Load BIOS Defaults
		F7 : Load Setup Defaults

The author assumes no responsibility for any errors or omissions which may appear in this document nor does it make a commitment to update the information contained herein.

IBM PC/AT, PC/XT are trademarks of International Business Machine Corporation.
PENTIUM is a trademark of Intel Corporation.
AWARD is a trademark of Award Software, Inc.
MS-DOS WINDOWS NT are registered trademarks of Microsoft Corporation.
UNIX is a trademark of Bell Laboratories.

OCTOBER 22, 1996 Taipei, Taiwan

TABLE OF CONTENTS

1. INTRODUCTION	1-1
1.1. PREFACE	1-1
1.2. KEY FEATURES	1-1
1.3. PERFORMANCE LIST	1-2
1.4. BLOCK DIAGRAM	1-4
1.5. INTRODUCE THE PCI - BUS	1-5
1.6. FEATURES	1-5
2. SPECIFICATION	2-1
2.1. HARDWARE	2-1
2.2. SOFTWARE	2-2
2.3. ENVIRONMENT	2-2
3. HARDWARE INSTALLATION	3-1
3.1. UNPACKING	3-1
3.2. MAINBOARD LAYOUT	3-2
3.3. QUICK REFERENCE FOR JUMPERS & CONNECTORS	3-2
3.4. DRAM INSTALLATION (EDO & F.P.)	3-4
DRAM Installation (SYNC. DRAM)	3-4
3.5. SRAM INSTALLATION	3-5
Sync. SRAM (PipeLine Burst SRAM)	3-5
3.6. CPU INSTALLATION AND JUMPERS SETUP	3-5
3.7. CMOS RTC & ISA CFG CMOS SRAM	3-6
3.8. SPEAKER CONNECTOR INSTALLATION	3-6
3.9. POWER LED CONNECTOR INSTALLATION	3-6
3.10. TURBO SWITCH CONNECTOR INSTALLATION	3-6
3.11. TURBO LED CONNECTOR INSTALLATION	3-6
3.12. HARDWARE RESET SWITCH CONNECTOR INSTALLATION	3-7
3.13. GREEN FUNCTION INSTALLATION	3-7
3.14. PERIPHERAL DEVICE INSTALLATION	3-7
3.15. KEYBOARD SETTING FUNCTION	3-7
4. BIOS CONFIGURATION	4-1
4.1. ENTERING SETUP	4-1
4.2. CONTROL KEYS	4-1

4.3. GETTING HELP	4-2
4.3.1. Main Menu	4-2
4.3.2. Status Page Setup Menu / Option Page Setup Menu	4-2
4.4. THE MAIN MENU	4-2
4.5. STANDARD CMOS SETUP MENU	4-4
4.6. BIOS FEATURES SETUP	4-7
4.7. CHIPSET FEATURES SETUP	4-10
4.8. POWER MANAGEMENT SETUP	4-13
4.9. PNP/PCI CONFIGURATION	4-15
4.10. LOAD BIOS DEFAULTS	4-16
4.11. LOAD SETUP DEFAULTS	4-17
4.12. INTEGRATED PERIPHERALS	4-18
4.13. SUPERVISOR / USER PASSWORD	4-21
4.14. IDE HDD AUTO DETECTION	4-22
4.15. HDD LOW LEVEL FORMAT	4-23
4.16. SAVE & EXIT SETUP	4-24
4.17. EXIT WITHOUT SAVING	4-25
5. AT TECHNICAL INFORMATION	5-1
5.1. I/O BUS Enhanced Parallel Port CONNECTOR PIN OUT	5-1
5.1.1. ISA SLOT PIN OUT	5-1
5.1.2. PCI - BUS SLOT PIN OUT	5-2
5.2. I/O & MEMORY MAP	5-3
5.3. TIMER & DMA CHANNELS MAP	5-3
5.4. INTERRUPT MAP	5-4
5.5. RTC & CMOS RAM MAP	5-5
APPENDIX A: POST MESSAGE	A-1
APPENDIX B: POST CODES	B-1
APPENDIX C: BIOS DEFAULT DRIVE TABLE	C-1
APPENDIX D: PROBLEM SHEET	D-1

1. INTRODUCTION

1.1. PREFACE

Welcome to use the **GA - 586SVX** motherboard. The motherboard is a Pipeline 256 KB / 512 KB CACHE PENTIUM™ Processor based PC / AT compatible system with ISA bus and PCI Local Bus, and has been designed to be the fastest PC / AT system. There are some new features allowing you to operate the system with just the performance you want.

This manual also explains how to install the motherboard for operation, and how to set up your CMOS CONFIGURATION with BIOS SETUP program.

1.2. KEY FEATURES

- ❑ Pentium® based PC / AT compatible mainboard with PCI - ISA Bus.
- ❑ 3 PCI Bus slots, 3 ISA Bus slots, 1 PCI / ISA slot.
- ❑ Supports Pentium processor running at 75-200 MHz, P54CT (125 / 150 / 166), P55C (150 / 166 / 200), P54CTB (150 / 166 / 180 / 200), AMDK5 (P-75 / P-90 / P-100), Cyrix 6x86-100 / 110 / 120 / 133 (P-120+ / P-133+ / P-150+ / P-166+).
- ❑ Supports true 64 bits CACHE and DRAM access mode.
- ❑ Supports 321 Pins (Socket 7) ZIF white socket on board.
- ❑ Supports 256 KB / 512 KB Pipeline Burst Sync. 2nd Cache.
- ❑ CPU L1 / L2 Write-Back cache operation.
- ❑ Supports 8 - 128 MB DRAM memory on board.
- ❑ Supports 1x168 pin 64/72 Bit DIMM module.
- ❑ Supports 2-channel Enhanced PCI IDE ports for 4 IDE Devices.
- ❑ Supports 2xCOM (16550), 1xLPT (EPP / ECP), 1x1.44MB Floppy port.
- ❑ Supports PS/2 Mouse port.
- ❑ Supports PS/2 Keyboard.
- ❑ Supports Green function, Plug & Play function.
- ❑ Licensed AWARD BIOS, FLASH EEPROM for BIOS update.
- ❑ BENCHMARK3287 / DALLAS 12887 / ODIN 12C887 RTC on board.
- ❑ ATX Form-Factor Layout, 4 layers PCB.
- ❑ Supports USB port. (optional)
- ❑ Supports Creative Vibra 1bc on board.
- ❑ Supports IRDA TX/RX Header (optional).

1.3. PERFORMANCE LIST

The following performance data list is the testing results of some popular benchmark testing programs. These data are just referred by users, and there is no responsibility for different testing data values gotten by users. (The different Hardware & Software configuration will result in different benchmark testing results.)

- CPU Pentium™ processor 133 / 166 MHz
- DRAM EDO 8MB 2pcs. Total 16 MB (Panasonic EUXSR08XX00E)
- CACHE SIZE 256 KB Pipeline Burst SRAM (UMC UM61L3232AF-7)
- DISPLAY Matrox Millennium
- STORAGE Onboard IDE port + Quantum Fireball 1280AT
- O.S. MS DOS V6.22 / Windows for workgroup 3.11

<DOS>

Program	Item	Unit	Pentium 133/66	Pentium 166/66
LandMark Speed	CPU	MHz	771.42	964.28
	FPU	MHz	2589.62	3237.06
V2.0	VIDEO	chr/ms	16384.00	16115
Power Meter	MIPS	Mips	67.6	83.6
	Dhrystone	K-Dstone/s	119.0	147.0
	Whetstone	K-Wstone/s	25623.4	32235.9
	Data Transfer Rate	KB/S	14073.9	14275.0
	Mean Seek	ms	10.3	10.3
	Track-Track Seek	ms	2.6	2.6
Norton System Info.	CPU	Index	423.5	529.4
	Disk	Index	22	21.9
Core Test	DATA Transfer Rate	KB/S	12416	12448
	Sequential Read	ms	6304	6288
	Random Read	ms	2384	2400
	Performance Index	Index	79.23	79.38
PC BenchMark	DOS Mark	Index	1121.33	1220.69
	CPU Mark16	Index	287.34	342.76
	Video Score	Index	6277.55	6266.21
	Disk Score	Index	607.13	639.53

< WINDOWS >- with Display Driver MGA Millennium power desktop1024 x 768 x 256 colors x 72Hz
- with Triones IDE Bus Master Driver Ver.3.20.

Program	Item	Unit	Pentium 133/66	Pentium 166/66
Winbench 95	Disk Winmark95	KB/s	1090	1100
	Graphics Winmark95	Mpixels/S	22.7	26
Winstone 95	Winstone95	Index	207.4	223.3
Winbench 96	CPU mark16		281	319
	CPU mark32		293	331
	Winbench 96		16.7	18.8
Winstone 96	Winstone 96		84.5	91.7

- CPU Pentium™ processor 133/166 MHz
- DRAM EDO 8MB 2pcs. Total 16 MB (Panasonic EUXSR08XX00E)
- CACHE SIZE 512 KB Pipeline Burst SRAM (UMC UM61L3232AF-7)
- DISPLAY Matrox Millennium
- STORAGE Onboard IDE port + Quantum Fireball 1280AT
- O.S. MS DOS V6.22 / Windows for workgroup 3.11

<DOS>

Program	Item	Unit	Pentium 133/66	Pentium 166/66	
LandMark Speed	CPU	MHz	771.42	964.28	
	FPU	MHz	2589.65	3237.09	
V2.0	VIDEO	chr/ms	16384.00	16115	
Power Meter	MIPS	Mips	67.7	83.6	
	Dhrystone	K-Dstone/s	119.0	147.0	
	Whetstone	K-Wstone/s	25623.4	32235.9	
	Data Transfer Rate	KB/S	14073.9	14275.0	
	Mean Seek	ms	10.2	10.3	
V1.81	Track-Track Seek	ms	2.6	2.6	
	Norton System Info.	CPU	Index	423.5	529.4
V8.0	Disk	Index	22.0	22	
Core Test	DATA Transfer Rate	KB/S	12448	12448	
	Sequential Read	ms	6304	6304	
	Random Read	ms	2384	2384	
	Performance Index	Index	79.43	79.43	
V.3.02	PC BenchMark	DOS Mark	Index	1123.68	1226.45
	V9.0	CPU Mark16	Index	289.47	347.66
		Video Score	Index	6261.62	6266.78
		Disk Score	Index	607	641.06

< WINDOWS >- with Display Driver MGA Millennium power desktop 1024 x 768 x 256 colors x 72Hz
 - with Triones IDE Bus Master Driver Ver.3.20.

Program	Item	Unit	Pentium 133/66	Pentium 166/66
Winbench 95	Disk Winmark95	KB/s	1150	1120
	Graphics Winmark95	Mpixels/S	23.3	26.8
Winstone 95	Winstone95	Index	210.2	225.9
Winbench 96	CPU mark16		292	337
	CPU mark32		311	351
	Winbench 96		16.9	18.7
Winstone 96	Winstone 96		85.1	93

1.4. BLOCK DIAGRAM

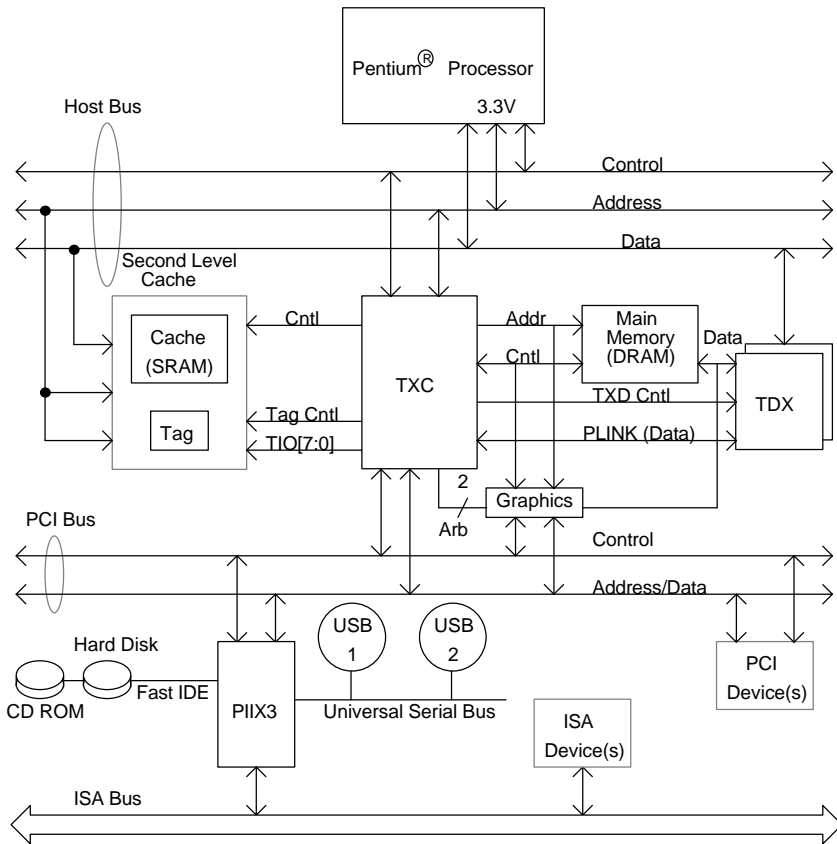

1.5. INTRODUCE THE PCI - BUS

Connecting devices to a CPU local bus can dramatically increase the speed of I/O-bound peripherals with only a slight increase in cost over traditional systems. This price / performance point has created a vast market potential for local bus products. The main barrier to this market has been the lack of an accepted standard for local bus peripherals. Many mainboard and chipset manufactures developed their own local bus implementations, but they are incompatible with each other. The VL (Video Electronics Standards Association) local bus and PCI (Peripheral Component Interconnect) bus specification was created to end this confusion.

The PCI - bus standard, under development since Jun. 1992, which is designed to bring workstation-level performance to standard PC platform. The PCI - bus removes many of the bottlenecks that have hampered PC for several years. On the PCI - bus, peripherals operate at the native speed of the computer system, thus enabling data transfer between peripherals and the system at maximum speed. This performance is critical for bandwidth-constrained devices such as video, multimedia, mass storage, and networking adapters.

PCI - bus standard provides end-users with a low-cost, extendible and portable local bus design, which will allow system and peripherals from different manufactures to work together.

1.6. FEATURES

- 32 bits bus transfer mode.
- Bus Master or Slave access.
- Memory burst transfer to 132 MB/sec.
- 33 MHz operation speed.
- 10 device loading ability.
- CPU independent.

2. SPECIFICATION

2.1. HARDWARE

- CPU
 - Pentium™ processor 75 - 200 MHz, P55C, P54CT, P54CTB, AMDK5(P-75 / P-90 / P-100), Cyrix6x86(P-120+ / P-133+ / P-150+ / P-166+).
 - 321 pins (socket 7) ZIF white socket on board.
 - 3.52V / 2.8V Dual Power Ready.
- COPROCESSOR
 - Included in Pentium.
- SPEED
 - 50 / 60 / 66 MHz system and 25 / 30 / 33 PCI-Bus speed.
 - 7.5 / 8 MHz AT bus speed.
 - Hardware and Software speed switchable function.
- DRAM MEMORY
 - 2 banks 72 pins SIMM module socket on board.
 - 1 banks 168 pins DIMM module socket on board
 - Use 4 / 8 / 16 / 32 MB 60~70 ns SIMM module DRAM.
 - 8 ~ 128 MB DRAM size.
 - Supports Fast Page / EDO DRAM access mode.
 - Supports 1x168 pin 64 / 72 bit DIMM module.
 - Supports PS/2 Keyboard.
 - IRDA TX/RX Header optional.
- CACHE MEMORY
 - 16 KB cache memory included in Pentium.
 - Pipeline Burst Sync. 2nd cache.
 - Supports Write Back cache function for both CPU & on board cache.
- SHADOW RAM
 - Shadow RAM cacheable function.
- SOUND
 - Supports creative VIBRA 16C.
- I/O BUS SLOTS
 - 4 Master / Slave PCI BUS.
 - 4 16-bit ISA BUS.
- IDE PORTS
 - 2-channel Enhanced IDE on board. (Using IRQ14, 15)
 - Supports Mode 3,4 IDE & ATAPI CD - ROM.
- I/O PORTS
 - Supports 2 16550 COM ports. (Using IRQ4, 3)
 - Supports 1 EPP/ECP LPT port. (Using IRQ7 or 5 and DMA3 or 1)
 - Supports 1 1.44MB Floppy port. (Using DMA2 & IRQ6)

- GREEN FUNCTION
 - Supports PS/2 Mouse. (Using IRQ12)
 - Supports Standby & Suspend mode.
 - Supports Green switch & LED.
 - Supports IDE & Display power down.
 - Monitors all IRQ / DMA / Display / I/O events.
- BIOS
 - 128KB FLASH EEPROM.
 - Supports Plug & Play Function.
- DIMENSION
 - ATX form-factor Layout 4 layers.

2.2. SOFTWARE

- BIOS
 - Licensed AWARD BIOS.
 - AT CMOS Setup, BIOS / Chipset Setup, Green Setup, Hard Disk Utility included.
- O.S.
 - Operation with MS-DOS V6.22, Windows for workgroup 3.11, Windows 95, WINDOWS NT 3.51, OS/2 Warp 3.0, NOVELL 3.12 / 4.01 / 4.1 and SCO UNIX 3.2.4.

2.3. ENVIRONMENT

- Ambient Temp.
 - 0°C to +50°C (Operating).
- Relative Hum.
 - 0 to +85% (Operating).
- Altitude
 - 0 to 10,000 feet (Operating).
- Vibration
 - 0 to 1,000 Hz.
- Electricity
 - 4.9 V to 5.2 V.

3. HARDWARE INSTALLATION

3.1. UNPACKING

The mainboard package should contain the following:

- The **GA - 586SVX** mainboard.
- USER'S MANUAL.
- Cable set for I/O Device.
- Diskette for BUS Master IDE Driver & Audio Driver.

The mainboard contains sensitive electric components which can be easily damaged by static electricity, so the mainboard should be left in its original packing until it is installed.

Unpacking and installation should be done on a grounded anti-static mat. The operator should be wearing an anti static wristband, grounded at the same point as the anti-static mat.

Inspect the mainboard carton for obvious damage. Shipping and handling may cause damage to your board. Be sure there are no shipping and handling damages on the board before proceeding.

After opening the mainboard carton, extract the system board and place it only on a grounded anti-static surface component side up. Again inspect the board for damage. Press down on all of the socket IC's to make sure that they are properly seated. Do this only on with the board placed on a firm flat surface.

⚠ DO NOT APPLY POWER TO THE BOARD IF IT HAS BEEN DAMAGED.

You are now ready to install your mainboard. The mounting hole pattern on the mainboard matches the IBM-AT system board. It is assumed that the chassis is designed for a standard IBM XT/AT mainboard mounting.

Place the chassis on the anti-static mat and remove the cover. Take the plastic clips, Nylon stand-off and screws for mounting the system board. Keep them separate.

◆ RST: Reset Switch	
Open	For normal operation.
Close	For hardware reset system.

◆ SPK: Speaker Connector	
Pin No.	Function
1	VCC.
2	NC.
3	NC.
4	Data.

◆ PWR: Power LED Connector	
Pin No.	Function
1	LED anode (+).
2	NC.
3	LED cathode (-).

◆ J15: Power Connector	
Pin No.	Function
1	Power Good signal
2,10,11,12	VCC (+5V)
3	+12V
4	-12V
5,6,7,8	GND
9	-5V

◆ J32: ATX Power Connector	
Pin No.	Function
12	-12V
10	+12V
9	5VSB
18	-5V
4,6,19,20	5V (VCC)
3,5,7,13.15.16.17	GND.
14	PS-ON
8	PW-OK

◆ JP18: CPU Cooling Fan Power Connector	
Pin No.	Function
1	+12V
2	GND

◆ SW: CPU INT./EXT. FREQ. RATIO					
SW1	SW2		SW3	SW4	MHz
OFF	OFF	X 1.5	ON	ON	50
ON	OFF	X 2	ON	OFF	55
ON	ON	X 2.5	OFF	ON	60
OFF	ON	X 3	OFF	OFF	66

◆ J2,3,4,22,24,25,26 I/O Ports Connector	
J22	For Floppy port
J24	For Primary IDE port
J25	For Secondary IDE port
J26	For LPT port
J31	For PS/2 Mouse port & PS/2 Keyboard Port.
J34	For COM A (Serial port1) & COM B (Serial port2)

3.4. DRAM INSTALLATION (EDO & F.P.)

The mainboard can be installed with 4 / 8 / 16 / 32 MB 72 pins SIMM module DRAM, and the DRAM speed must be 60 or 70 ns. The DRAM memory system on mainboard consists of bank 0, & bank 1. Each bank consists of 2 sockets for 72 pins SIMM module DRAM. Because the 72 pins SIMM module is 32 bits width, using 2 PCs which can match a 64 bits system. The total memory size is 8 - 128 MB.

For the DRAM installation position, please refer to Figure 3.1. Note that the Pin 1 of SIMM module must match with the Pin 1 of SIMM socket when the DRAM SIMM module is installed.

Insert the DRAM SIMM module into the SIMM socket at 45 degree angle. If there is a wrong direction of Pin 1, the DRAM SIMM module couldn't be inserted into socket completely. After completely insert SIMM module into socket, then press the SIMM module in vertical direction until the left and right metal holders can keep the SIMM module standing up firmly.

DRAM Installation (SYNC. DRAM)

The mainboard can be installed with 8 / 16 / 32 / 64 MB Sync. DRAM. The Sync. DRAM memory system on mainboard consists of DIMM1 only.

For the Sync. DRAM installation position, please refers to Figure 3.1. Note that the Pin 1 of DIMM module must match with the Pin 1 of DIMM socket when the Sync. DRAM DIMM module is installed.

DRAM configuration table:

BANK0 (SIMM 1 & 2)	BANK1 (SIMM 3 & 4)	TOTAL SIZE	DIMM 1	TOTAL SIZE
4MB * 2pcs.		8 MB	8MB	8MB
4MB * 2pcs.	4MB * 2pcs.	16MB	16MB	16MB
8MB * 2pcs.		16MB	32MB	32MB
8MB * 2pcs.	4MB * 2pcs.	24MB	64MB	64MB
8MB * 2pcs.	8MB * 2pcs.	32MB		
16MB * 2pcs.		32MB		
16MB * 2pcs.	4MB * 2pcs.	40MB		
16MB * 2pcs.	8MB * 2pcs.	48MB		
16MB * 2pcs.	16MB * 2pcs.	64MB		
32MB * 2pcs.		64MB		
32MB * 2pcs.	4MB * 2pcs.	72MB		
32MB * 2pcs.	8MB * 2pcs.	80MB		
32MB * 2pcs.	16MB * 2pcs.	96MB		
32MB * 2pcs.	32MB * 2pcs.	128MB		

3.5. SRAM INSTALLATION

Sync. SRAM (PipeLine Burst SRAM)

If Sync SRAM Module is installed, it consists of Pipeline Burst 2 PCs 32 K x 32 from 256K upgradable to 512K.

There is no jumper for cache size setting.

3.6. CPU INSTALLATION AND JUMPERS SETUP

The system speed depends on the frequency of CLOCK GENERATOR. The user can change SW1 selection to set up the system speed to 50 MHz, 60 MHz or 66 MHz for 3.3V/2.5V Pentium Processor (75-200 MHz) / AMDK5(P-75 / P-90) / Cyrix 6x86 (P-120+ / P-150+ / P-166+).

The mainboard can use PENTIUM processor, P54CT, P55C or P54CTB, AMDK5, Cyrix6x86 CPU, and the CPU speed must match with the frequency of CLOCK GEN. It will cause system hanging up if the CLOCK GEN.'S

frequency is faster than CPU's.

- **The CPU is a sensitive electric component and it can be easily damaged by static electricity, so users must keep it away from metal surface when the CPU is installed onto mainboard.**
- **When the user installs the CPU on socket, please notice that the PIN 1 of CPU is in the same corner as the PIN 1 of socket!**
- **Before the CPU is installed, the mainboard must be placed on a flat plane in order to avoid being broken by the pressure of CPU installation.**

3.7. CMOS RTC & ISA CFG CMOS SRAM

There're RTC & CMOS SRAM on board, they have a power supply from internal battery to keep the DATA inviolate & effective. The RTC is a REAL-TIME CLOCK device which provides the DATE & TIME to the system. The CMOS SRAM is used for keeping the information of ISA device system configuration, so the system can automatically boot OS every time.

Due to the fact that the life-time of RTC internal battery is 5 years, the user can change a new RTC to replace old one after it does not work. The new one's brand and type must be same with the old one.

3.8. SPEAKER CONNECTOR INSTALLATION

There is always a speaker in AT system for sound purpose. The 4 - Pins connector **SPK** is used to connect speaker. The speaker can work well in both direction of connector when it is installed to the connector **SPK** on mainboard.

3.9. POWER LED CONNECTOR INSTALLATION

There is a system power LED light on the panel of case. The power LED will light on when system is powered-on. The connector should be installed to **PWR** of mainboard in correct direction.

3.10. TURBO SWITCH CONNECTOR INSTALLATION

The TURBO switch on the panel is used for controlling the system speed. Some program developed on XT should be executed with a low speed system, so a high speed system needs the speed switching function to change its running speed.

The mainboard uses 50 MHz speed method to implement TURBO switching function. The **TB** on mainboard should be connected to the TURBO switch on panel, and user can push in or pop out the TURBO switch to enable or

disable the turbo function of system.

● **Please don't use switch ON/OFF when power is ON.**

3.11. TURBO LED CONNECTOR INSTALLATION

The TURBO LED on panel can indicate the current speed status of system. The TURBO LED connector should be installed to **TD** in correct direction.

3.12. HARDWARE RESET SWITCH CONNECTOR INSTALLATION

The RESET switch on panel provides users with HARDWARE RESET function which is almost the same as power-on/off. The system will do a cold start after the RESET switch is pushed and released by user. The RESET switch is a 2 PIN connector and should be installed to **RST** on mainboard.

3.13. GREEN FUNCTION INSTALLATION

For the purpose of power saving, there are two jumpers, **GN** and **GD**, to make sure that the power saving function is working. The **GD** is an indicator (green LED) for green function. If the green LED is ON, the system is operating in green mode. The **GN** is a switch to force the system to get into green mode immediately.

3.14. PERIPHERAL DEVICE INSTALLATION

After installation of the device and setup of the jumpers, the mainboard can be mounted into the case and fixed by screw. To complete the mainboard installation, the peripheral devices could be installed now. The basic system needs a display interface card and a storage device.

If a PCI - Bus device is to be installed in the system, any one of four PCI - Bus slots can be used for Slave or Master PCI - Bus device.

After installing the peripheral device, the user should check everything again and prepare to power-on the system.

3.15. KEYBOARD SETTING FUNCTION

After booting the O.S., there are some special functions used by keyboard as follows:

"CTRL_ALT_DEL"	- Pressing these keys simultaneously will cause system to Warm Start (Software Reset).
----------------	--

4. BIOS CONFIGURATION

Award's BIOS ROM has a built-in Setup program that allows users to modify the basic system configuration. This type of information is stored in battery-backed CMOS SRAM so that it retains the Setup information when the power is turned off.

4.1. ENTERING SETUP

To Power ON the computer and press immediately will allow you to enter Setup. The other way to enter Setup is to power on the computer. When the below message appears briefly at the bottom of the screen during the POST (Power On Self Test), press key or simultaneously press <Ctrl>, <Alt>, and <Esc> keys.

• **TO ENTER SETUP BEFORE BOOT PRESS CTRL-ALT-ESC OR DEL KEY**

If the message disappears before you respond and you still wish to enter Setup, restart the system to try again by turning it OFF then ON or pressing the "RESET" bottom on the system case. You may also restart by simultaneously pressing <Ctrl>,<Alt>, and keys. If you do not press the keys at the correct time and the system does not boot, an error message will be displayed and you will again be asked to,

• **PRESS F1 TO CONTINUE, CTRL-ALT-ESC OR DEL TO ENTER SETUP**

4.2. CONTROL KEYS

Up arrow	Move to previous item
Down arrow	Move to next item
Left arrow	Move to the item in the left hand
Right arrow	Move to the item in the right hand
Esc key	Main Menu - Quit and not save changes into CMOS Status Page Setup Menu and Option Page Setup Menu - Exit current page and return to Main Menu
PgUp key	Increase the numeric value or make changes
PgDn key	Decrease the numeric value or make changes
F1 key	General help, only for Status Page Setup Menu and Option Page Setup Menu
F2 key	Change color from total 16 colors
F3 key	Calendar, only for Status Page Setup Menu
F4 key	Reserved
F5 key	Restore the previous CMOS value from CMOS, only for Option Page Setup Menu
F6 key	Load the default CMOS value from BIOS default table, only for Option Page Setup Menu
F7 key	Load the default
F8 key	Reserved
F9 key	Reserved
F10 key	Save all the CMOS changes, only for Main Menu

4.3. GETTING HELP

4.3.1. Main Menu

The on-line description of the highlighted setup function is displayed at the bottom of the screen.

4.3.2. Status Page Setup Menu / Option Page Setup Menu

Press F1 to pop up a small help window that describes the appropriate keys to use and the possible selections for the highlighted item. To exit the Help Window press <Esc>.

4.4. THE MAIN MENU

Once you enter Award BIOS CMOS Setup Utility, the Main Menu (Figure 4.1) will appear on the screen. The Main Menu allows you to select from twelve setup functions and two exit choices. Use arrow keys to select among the items and press <Enter> to accept or enter the sub-menu.

ROM PCI / ISA BIOS
 CMOS SETUP UTILITY
 AWARD SOFTWARE, INC.

STANDARD CMOS SETUP	INTEGRATED PERIPHERALS
BIOS FEATURES SETUP	SUPERVISOR PASSWORD
CHIPSET FEATURES SETUP	USER PASSWORD
POWER MANAGEMENT SETUP	IDE HDD AUTO DETECTION
PNP/PCI CONFIGURATION	HDD LOW LEVEL FORMAT
LOAD BIOS DEFAULTS	SAVE & EXIT SETUP
LOAD SETUP DEFAULTS	EXIT WITHOUT SAVING
ESC : Quit	↑ ↓ → ← : Select Item
F10 : Save & Exit Setup	(Shift)F2 : Chang Color
Time, Date, Hard Disk Type, ...	

Figure 4.1: Main Menu

- Standard CMOS setup
This setup page includes all the items in a standard compatible BIOS.
- BIOS features setup
This setup page includes all the items of Award special enhanced features.
- Chipset features setup
This setup page includes all the items of chipset special features.
- Power management setup
This setup page includes all the items of Green function features.
- PNP/PCI configuration
This setup page includes all the items of PNP/PCI configuration features.
- Load BIOS defaults
BIOS defaults indicates the most appropriate value of the system parameter which the system would be in safe configuration.
- Load setup defaults
BIOS defaults indicates the most appropriate value of the system parameter which the system would be in safe configuration.
- Integrated Peripherals
This setup page includes all the items of peripherals features.
- Supervisor Password
Change, set, or disable password. It allows you to limit access to the system and Setup, or just to Setup.
- User Password
Change, set, or disable password. It allows you to limit access to the system.
- IDE HDD auto detection
Automatically configure hard disk parameter.
- HDD low level format
Low level format IDE Hard Disk.
- Save & exit setup
Save CMOS value changes to CMOS and exit setup.
- Exit without save
Abandon all CMOS value changes and exit setup.

4.5. STANDARD CMOS SETUP MENU

The items in Standard CMOS Setup Menu (Figure 4.2) are divided into 8 categories. Each category includes no, one or more than one setup items. Use the arrows to highlight the item and then use the <PgUp> or <PgDn> keys to select the value you want in each item.

ROM PCI / ISA BIOS
STANDARD CMOS SETUP
AWARD SOFTWARE, INC.

Date (mm:dd:yy) Fri, Mar 1 1996
Time (hh:mm:ss) 16 : 49 : 18

HARD DISKS	TYPE	SIZE	CYLS	HEAD	PRECOMP	LANDZ	SECTOR	MODE
Primary Master	: Auto	0	0	0	0	0	0	AUTO
Primary Slave	: None	0	0	0	0	0	0	-----
Secondary Master	: None	0	0	0	0	0	0	-----
Secondary Slave	: None	0	0	0	0	0	0	-----

Drive A : 1.44M , 3.5 in.
Drive B : None
Floppy 3 Mode Support : Disabled

Video : EGA/VGA
Halt On : No Errors

Base Memory: 640 K
Extended Memory: 15360 K

Other Memory: 384 K

Total Memory: 16384 K

ESC : Quit ↑ ↓ → ← : Select Item PU/PD/+/- : Modify
F1 : Help (Shift)F2 : Chang Color

Figure 4.2: Standard CMOS Setup Menu

- Date

The date format is <day>, <date> <month> <year>. Press <F3> to show the calendar.

day	The day, from Sun to Sat, determined by the BIOS and is display-only
date	The date, from 1 to 31 (or the maximum allowed in the month)
month	The month, Jan. through Dec.
year	The year, from 1900 through 2099

- Time

The time format in <hour> <minute> <second>. The time is calculated base on the 24-hour military-time clock. For example, 1 p.m. is 13:00:00.

- Primary HDDs / Secondary HDDs

The category identify the types of hard disk drive that has been installed in the computer. There are 45 pre-defined types and a user definable type. Type 1 to Type 45 are pre-defined. Type User is user-definable and type Auto will automatically detect HDD's type..

Press PgUp or PgDn to select a numbered hard disk type or type the number and press <Enter>. Note that the specifications of your drive must match with the drive table. The hard disk will not work properly if you enter improper information for this category. If your hard disk drive type is not matched or listed, you can use Type User to define your own drive type manually.

If you select Type User, related information is asked to be entered to the following items. Enter the information directly from the keyboard and press <Enter>. Those information should be provided in the documentation form of your hard disk vendor or the system manufacturer.

CYLS.	number of cylinders
HEADS	number of heads
PRECOMP	write precomp
LANDZONE	landing zone
SECTORS	number of sectors

If a hard disk has not been installed select NONE and press <Enter>.

- Drive A type / Drive B type

The category identify the types of floppy disk drive A or drive B that has been installed in the computer.

None	No floppy drive installed
360K, 5.25 in.	5-1/4 inch PC-type standard drive; 360 kilobyte capacity.
1.2M, 5.25 in.	5-1/4 inch AT-type high-density drive; 1.2 megabyte capacity (3-1/2 inch when 3 Mode is Enabled).
720K, 3.5 in.	3-1/2 inch double-sided drive; 720 kilobyte capacity
1.44M, 3.5 in.	3-1/2 inch double-sided drive; 1.44 megabyte capacity.
2.88M, 3.5 in.	3-1/2 inch double-sided drive; 2.88 megabyte

	capacity.
--	-----------

- Floppy 3 Mode Support

Disabled	No 3 mode floppy drive installed.
Drive A	Installed 3 mode drive at drive A.
Drive B	Installed 3 mode drive at drive B.
Both	Installed 3 mode drive at drive A and drive B.

- Video

The category detects the type of adapter used for the primary system monitor that must match your video display card and monitor. Although secondary monitors are supported, you do not have to select the type in setup.

EGA/VGA	Enhanced Graphics Adapter/Video Graphics Array. For EGA, VGA, SVGA, or PGA monitor adapters
CGA 40	Color Graphics Adapter, power up in 40 column mode
CGA 80	Color Graphics Adapter, power up in 80 column mode
MONO	Monochrome adapter, includes high resolution monochrome adapters

- Halt on

The category determines whether the computer will stop if an error is detected during power up.

NO errors	The system boot will not be stopped for any error that may be detected
All errors	Whenever the BIOS detects a non-fatal error the system will be stopped and you will be prompted
All,But Keyboard	The system boot will not stop for a keyboard error; it will stop for all other errors
All, But Diskette	The system boot will not stop for a disk error; it will stop for all other errors
All, But Disk/Key	The system boot will not stop for a keyboard or disk error; it will stop for all other errors

- Memory

The category is display-only which is determined by POST (Power On Self Test) of the BIOS.

Base Memory

The POST of the BIOS will determine the amount of base (or conventional) memory installed in the system. The value of the base memory is typically 512K for systems with 512K memory installed on the motherboard, or 640K for systems with 640K or

more memory installed on the motherboard.

Extended Memory

The BIOS determines how much extended memory is presented during the POST. This is the amount of memory located above 1MB in the CPU's memory address map.

Expanded Memory

Expanded Memory is defined by the Lotus/Intel/Microsoft (LIM) standard as EMS. Many standard DOS applications can not utilize memory above 640K. The Expanded Memory Specification (EMS) swaps memory which is not utilized by DOS with a section, or frame, so these applications can access all of the system memory. Memory which can be swapped by EMS is usually 64K within 1MB or memory above 1MB, depending on the chipset design.

Expanded memory device driver is required to use memory as Expanded Memory.

Other Memory

This refers to the memory located in the 640K to 1024 K address space. This is memory that can be used for different applications. DOS uses this area to load device drivers to keep as much base memory free for application programs. Most usage for this area is Shadow RAM.

4.6. BIOS FEATURES SETUP

ROM PCI / ISA BIOS
 BIOS FEATURES SETUP
 AWARD SOFTWARE, INC.

Virus Warning	: Disabled	Video BIOS Shadow	: Enabled
CPU Internal Cache	: Enabled	C8000 - CBFFF Shadow	: Disabled
External Cache	: Enabled	CC000 - CFFFF Shadow	: Disabled
Quick Power On Self Test	: Enabled	D0000 - D3FFF Shadow	: Disabled
Boot Sequence	: A, C	D4000 - D7FFF Shadow	: Disabled
Swap Floppy Drive	: Disabled	D8000 - DBFFF Shadow	: Disabled
Boot Up Floppy Seek	: Enabled	DC000 - DFFFF Shadow	: Disabled
Boot Up NumLock Status	: On		
Security Option	: Setup		
PCL/VGA Palette Snoop	: Disabled		
OS Select For DRAM >64MB	: Non-OS2		
		ESC : Quit ↑ ↓ → ← : Select Item F1 : Help PU/PD/+/- : Modify F5 : Old Values (Shift)F2 : Color F6 : Load BIOS Defaults F7 : Load Setup Defaults	

Figure 4.3: BIOS Features Setup

- Virus Warning

This category flashes on the screen. During and after the system boots up, any attempt to write to the boot sector or partition table of the hard disk drive will halt the system and the following error message will appear. In the mean time, you can run anti-virus program to locate the problem. Default value is Disabled.

Enabled	Activate automatically when anything attempts to access the boot sector or hard disk partition table. Which is informed by a warning message.
Disabled	No warning message appears when anything attempts to access the boot sector or hard disk partition table

- CPU Internal Cache / External Cache

These two categories speed up memory access. However, it depends on CPU / chipset design. The default value is Enabled.

Enabled	Enable cache function.
Disabled	Disable cache function.

- Quick Power On Self Test

This category speeds up Power On Self Test (POST) after you power on the computer. If it is set to Enable, BIOS will skip some check items during POST. The default value is Enabled.

Enabled	Enable quick POST
Disabled	Normal POST

- Boot Sequence

This category determines which drive computer searches first for the disk operating system (i.e., DOS). Default value is A,C.

A,C	System will first search for floppy disk drive then hard disk drive.
C,A	System will first search for hard disk drive then floppy disk drive.

- Swap Floppy Drive

The default value is Disabled.

Enabled	Floppy A & B will be swapped under DOS
Disabled	Floppy A & B will be normal definition

- Boot Up Floppy Seek

During POST, BIOS will determine if the floppy disk drive installed is 40 or 80 tracks. 360 KB type is 40 tracks while 720 KB, 1.2 MB, 1.44 MB and 2.88 MB are all 80 tracks. The default value is Enabled.

Enabled	BIOS searches for floppy disk drive to determine if it is 40 or 80 tracks, Note that BIOS can not tell from 720 KB, 1.2 MB, 1.44 MB and 2.88 MB drive type as they are all 80 tracks.
Disabled	BIOS will not search for the type of floppy disk drive by track number. Note that there will not be any warning message if the drive installed is 360 KB.

- Boot Up NumLock Status

The default value is On.

On	Keypad is number keys
Off	Keypad is arrow keys

- Security Option

This category allows you to limit access to the system and Setup, or just to Setup. The default value is Setup.

System	The system will not boot and access to Setup will be denied if the correct password is not entered at the prompt
Setup	The system will boot, but access to Setup will be denied if the correct password is not entered at the prompt

- **To disable security, select PASSWORD SETTING at Main Menu and then you will be asked to enter password. If the user does not type anything and just press <Enter>, it will disable security. Once the security is disabled, the system will boot and you can enter Setup freely.**

- PCI/VGA Palette Snoop

The default value is Disabled.

Enabled	For having Video Card on ISA BUS and VGA Card on PCI BUS.
Disabled	For VGA Card only.

- OS Select For DRAM>64MB

The default value is Non-OS2.

Non-OS2	Using non-OS2 operating system.
OS2	Using OS2 operating system and DRAM>64MB.

- Video BIOS Shadow

It determines whether video BIOS will be copied to RAM, however, it is optional from chipset design. Video Shadow will increase the video speed. The default value is Enable.

Enabled	Video shadow is enabled.
Disabled	Video shadow is disabled.

- C8000 - CFFFF Shadow / D0000 - DFFFF Shadow

These categories determine whether optional ROM will be copied to RAM by 16 K byte. The default value are Disabled.

Enabled	Optional shadow is enabled.
Disabled	Optional shadow is disabled.

4.7. CHIPSET FEATURES SETUP

ROM PCI / ISA BIOS
 CHIPSET FEATURES SETUP
 AWARD SOFTWARE, INC.

* Auto Configuration : Enabled * DRAM Timing : 70 ns DRAM RAS# Precharge Time : 4 DRAM R/W Leadoff Timing : 7 Fast RAS To CAS Delay : 3 DRAM Read Burst (EDO/FP) : x222/x333 DRAM Write Burst Timing : x333 Fast MA to RAS# Delay CLK : 2 Refresh RAS# Assertion : 5 CLKS ISA Bus Clock : PCI CLK/4 Pipeline Cache Timing : Faster System BIOS Cacheable : Enabled Video BIOS Cacheable : Enabled 8 Bit I/O Recovery Time : 1 16 Bit I/O Recovery Time : 1 Memory Hole At 15M-16M : Disabled Peer Concurrency : Enabled ** SDRAM (CAS Lat/RAS-to CAS) : 3/3	ESC : Quit ↑ ↓ → ← : Select Item F1 : Help PU/PD/+/- : Modify F5 : Old Values (Shift)F2 : Color F6 : Load BIOS Defaults F7 : Load Setup Defaults
--	--

Figure 4.4: Chipset Features Setup

* This option will show up if Auto configuration is been Enabled.

** This option will show up if SDRAM is using.

- Auto Configuration

The default value is Enabled.

Enabled	Enable auto configuration.
Disabled	Disable auto configuration.

- DRAM Timing

The default value is 70 ns.

60 ns	Using 60ns DRAM speed.
70 ns	Using 70ns DRAM speed.

- DRAM RAS# Precharge Time

The default value is 4.

3	Set DRAM RAS# precharge time to 3.
4	Set DRAM RAS# precharge time to 4.

- DRAM R/W Leadoff Timing

The default value is 7.

7	Set DRAM R/W leadoff timing to 7.
6	Set DRAM R/W leadoff timing to 6.

- Fast RAS To CAS Delay

The default value is 3.

2	Set Fast RAS to CAS delay to 2.
3	Set Fast RAS to CAS delay to 3.

- DRAM Read Burst (EDO/FP)

The default value is x444/x444.

x444/x444	Set DRAM read burst to x444/x444.
x333/x444	Set DRAM read burst to x333/x444.
x222/x333	Set DRAM read burst to x222/x333.

- DRAM write Burst timing

The default value is x444.

x222	Set DRAM write burst timing to x222.
x333	Set DRAM write burst timing to x333.
x444	Set DRAM write burst timing to x444.

- Fast MA to RAS# Delay CLK

The default value is 2.

2	Set Fast MA to RAS# Delay 2 CLK.
1	Set Fast MA to RAS# Delay 1 CLK.

- Refresh RAS# Assertion

The default value is 5 CLKS.

4	Set Refresh RAS# Assertion to 4 CLKS
5	Set Refresh RAS# Assertion to 5 CLKS

- ISA Bus Clock

The default value is PCICLK/3.

PCICLK/3	For 50 MHz system.
PCICLK/4	For 66,60 MHz system.

- Pipeline Cache Timing

The default value is Faster.

Faster	Set Pipeline Cache Timing to Faster.
Fastest	Set Pipeline Cache Timing to Fastest.

- System BIOS Cacheable

The default value is Enabled.

Enabled	Enable system BIOS cacheable.
Disabled	Disable system BIOS cacheable.

- Video BIOS Cacheable

The default value is Enabled.

Enabled	Enable video BIOS cacheable.
Disabled	Disable video BIOS cacheable.

- 8 Bit I/O Recovery Time

The default value is 1.

1~8	Set 8 Bit I/O recovery time from 1 to 8.
NA	None.

- 16 Bit I/O Recovery Time

The default value is 1.

1~4	Set 16 Bit I/O recovery time from 1 to 4.
NA	None.

- Memory Hole At 15M-16M

The default value is Disabled.

Disabled	Normal Setting.
Enabled	Set Address=15~16MB relocate to ISA BUS.

- Peer Concurrency

The default value is Enabled.

Disabled	Disable peer concurrency.
Enabled	Enable peer concurrency.

- SDRAM (CAS Lat/RAS-to CAS)

The default value is 3/3.

3/3	SDRAM (CAS Lat/RAS-to CAS) is 3/3.
3/2	SDRAM (CAS Lat/RAS-to CAS) is 3/2.
2/2	SDRAM (CAS Lat/RAS-to CAS) is 2/2.

4.8. POWER MANAGEMENT SETUP

ROM PCI / ISA BIOS
POWER MANAGEMENT SETUP
AWARD SOFTWARE, INC.

Power Management	: Enabled	** Power Down & Resume Events **	
PM Control by APM	: Yes	IRQ3 (COM 2)	: ON
Video Off Method	: DPMS	IRQ4 (COM 1)	: ON
Standby Mode	: Disabled	IRQ5 (LPT 2)	: OFF
Suspend Mode	: Disabled	IRQ6 (Floppy Disk)	: ON
HDD Power Down	: Disabled	IRQ7 (LPT 1)	: OFF
** Wake Up Events In Standby **		IRQ9 (IRQ2 Redir)	: OFF
IRQ3 (Wake-Up Event)	: ON	IRQ10 (Reserved)	: OFF
IRQ4 (Wake-Up Event)	: ON	IRQ11 (Reserved)	: ON
IRQ12 (Wake-Up Event)	: ON	IRQ12 (PS/2 Mouse)	: ON
		IRQ14 (Hard Disk)	: ON
		IRQ15 (Reserved)	: ON
		ESC : Quit ↑ ↓ → ← : Select Item	
		F1 : Help PU/PD/+/- : Modify	
		F5 : Old Values (Shift)F2 : Color	
		F6 : Load BIOS Defaults	
		F7 : Load Setup Defaults	

Figure 4.5: Power Management Setup

- Power Management

The default value is Enabled.

Enabled	Enable Green function.
Disabled	Disable Green function.

Please disable Green Function for Non-S CPU in OS/2, Unix, Window NT & Novell system.

- PM Control by APM

The default value is Yes.

Yes	Enable software APM function.
No	Disable software APM function.

- Video off Method

The default value is DPMS.

V/H SYNC+Blank	BIOS will turn off V/H-SYNC when gets into Green mode for Green monitor power saving.
Blank Screen	BIOS will only black monitor when gets into Green mode.
DPMS	BIOS will use DPMS Standard to control VGA card. (The Green type VGA card will turn of V/H-SYNC automatically.)

- Standby Mode

The default value is Disable.

Disable	Disable Standby Mode.
1 min - 1 Hour	Setup the timer to enter Standby Mode.

- Suspend mode

The default value is Disable.

Disable	Disable Suspend Mode.
1 min - 1 Hour	Setup the timer to enter Suspend Mode.

- HDD Power Down

The default value is Disable.

Disable	Disable HDD Power Down mode function.
1-15 mins	Enable HDD enter Power Down mode between 1 to 15 mins.

- IRQX (3,4,5,6,7,9,10,11,12,14,15)

The default value is On.

On	The system will return to normal mode from Green Mode when the IRQX is active.
Off	The system will not return to normal mode from Green Mode when the IRQX is active.

4.9. PNP/PCI CONFIGURATION

ROM PCI / ISA BIOS
 PNP/PCI CONFIGURATION
 AWARD SOFTWARE, INC.

Resources Controlled By	: Manual	PCI IRQ Activated By	: Level
Reset Configuration Data	: Disabled	PCI IDE IRQ Map To	: PCI-AUTO
IRQ-3 assigned to	: Legacy ISA	Primary IDE INT#	: A
IRQ-4 assigned to	: Legacy ISA	Secondary IDE INT#	: B
IRQ-5 assigned to	: PCI/ISA PnP		
IRQ-7 assigned to	: Legacy ISA		
IRQ-9 assigned to	: PCI/ISA PnP		
IRQ-10 assigned to	: PCI/ISA PnP		
IRQ-11 assigned to	: PCI/ISA PnP		
IRQ-12 assigned to	: Legacy ISA		
IRQ-14 assigned to	: Legacy ISA		
IRQ-15 assigned to	: Legacy ISA		
DMA-0 assigned to	: PCI/ISA PnP		
DMA-1 assigned to	: PCI/ISA PnP		
DMA-3 assigned to	: PCI/ISA PnP		
DMA-5 assigned to	: PCI/ISA PnP		
DMA-6 assigned to	: PCI/ISA PnP		
DMA-7 assigned to	: PCI/ISA PnP		

ESC : Quit	↑ ↓ → ← : Select Item
F1 : Help	PU/PD/+/- : Modify
F5 : Old Values	(Shift)F2 : Color
F6 : Load BIOS Defaults	
F7 : Load Setup Defaults	

Figure 4.6: PNP/PCI Configuration

- Resources Controlled By

The default value is Manual.

Manual	Disable resources controlled.
Auto	Enable resources controlled.

- Reset Configuration Data

The default value is Disabled.

Disabled	Disable reset configuration data.
Enabled	Enable reset configuration data.

- Assigned to IRQ(3,4,5,7,9,10,11,12,14,15) / DMA (0,1,3,5,6,7)

Legacy ISA	Assigned IRQX/DMAX to ISA Bus.
PCI/ISA PnP	Assigned IRQX/DMAX to PCI/ISA Bus with PnP function.

- PCI IRQ Activated By

Level	For some PCI SCSI or Lan device using same PCI INT.
Edge	Normal operating.

- PCI IDE IRQ Map To

4.11. LOAD SETUP DEFAULTS

ROM PCI / ISA BIOS
 CMOS SETUP UTILITY
 AWARD SOFTWARE, INC.

STANDARD CMOS SETUP	INTEGRATED PERIPHERALS
BIOS FEATURES SETUP	SUPERVISOR PASSWORD
CHIPSET FEATURES SETUP	USER PASSWORD
POWER MANAGEMENT SETUP	IDE HDD AUTO DETECTION
PNP/PCI CONFIGURATION	FORMAT
LOAD BIOS DEFAULTS	LOAD SETUP
LOAD SETUP DEFAULTS	EXIT WITHOUT SAVING
ESC : Quit F10 : Save & Exit Setup	
↑ ↓ → ← : Select Item (Shift)F2 : Chang Color	
Load Setup Defaults except Standard CMOS SETUP	

Figure 4.8: Load Setup Defaults

- Load SETUP Defaults
 To load SETUP defaults value to CMOS SRAM, enter "Y". If not, enter "N".
- **If there is any problem occurred, loading SETUP DEFAULTS step is recommended.**

4.12. INTEGRATED PERIPHERALS

ROM PCI / ISA BIOS
INTEGRATED PERIPHERALS
AWARD SOFTWARE, INC.

IDE HDD Block Mode	: Enabled	ESC : Quit ↑ ↓ → ← : Select Item F1 : Help PU/PD/+/- : Modify F5 : Old Values (Shift)F2 : Color F6 : Load BIOS Defaults F7 : Load Setup Defaults
IDE Primary Master PIO	: Auto	
IDE Primary Slave PIO	: Auto	
IDE Secondary Master PIO	: Auto	
IDE Secondary Slave PIO	: Auto	
On-Chip Primary PCI IDE	: Enabled	
On-Chip Secondary PCI IDE	: Enabled	
Onboard FDD Controller	: Enabled	
Onboard Serial Port 1	: 3F8/IRQ4	
Onboard Serial Port 2	: 2F8/IRQ3	
Onboard Parallel Port	: 378H/IRQ7	
Onboard Parallel Mode	: SPP	
* ECP Mode Use DMA	: 3	
** Parallel Port EPP type	: EPP 1.7	

Figure 4.9: Integrated Peripherals

- * This item will show up only if On board Parallel Mode set to ECP or ECP/EPP.
- ** This item will show up only if On board Parallel Mode set to EPP/SPP or ECP/EPP.

- IDE HDD Block Mode
The default value is Enabled.

Enabled	Enable IDE HDD Block Mode
Disabled	Disable IDE HDD Block Mode

- IDE Primary Master PIO (for onboard IDE 1st channel).
The default value is Auto.

Auto	BIOS will automatically detect the IDE HDD Accessing mode.
Mode0~4	Manually set the IDE Accessing mode.

- IDE Primary Slave PIO (for onboard IDE 1st channel).
The default value is Auto.

Auto	BIOS will automatically detect the IDE HDD Accessing mode.
Mode0~4	Manually set the IDE Accessing mode.

- IDE Secondary Master PIO (for onboard IDE 2nd channel).

The default value is Auto.

Auto	BIOS will automatically detect the IDE HDD Accessing mode.
Mode0~4	Manually set the IDE Accessing mode.

- IDE Secondary Slave PIO (for onboard IDE 2nd channel).

The default value is Auto.

Auto	BIOS will automatically detect the IDE HDD Accessing mode.
Mode0~4	Manually set the IDE Accessing mode.

- On-chip Primary/Secondary PCI IDE

The default value is Enabled.

Enabled	Enable On-chip Primary/Secondary PCI IDE.
Disabled	Disable On-chip Primary/Secondary PCI IDE.

- Onboard FDD Controller

The default value is Enabled.

Enabled	Enable onboard FDD port.
Disabled	Disable onboard FDD port.

- Onboard Serial Port 1

The default value is 3F8/IRQ4.

3F8/IRQ4	Enable onboard Serial port 1 and address is 3F8H.
2F8/IRQ3	Enable onboard Serial port 1 and address is 2F8H.
3E8/IRQ4	Enable onboard Serial port 1 and address is 3E8H.
2E8/IRQ3	Enable onboard Serial port 1 and address is 2E8H.
Disabled	Disable onboard Serial port 1.

- Onboard Serial Port 2

The default value is 2F8/IRQ3.

3F8/IRQ4	Enable onboard Serial port 2 and address is 3F8H.
2F8/IRQ3	Enable onboard Serial port 2 and address is 2F8H.
3E8/IRQ4	Enable onboard Serial port 2 and address is 3E8H.
2E8/IRQ3	Enable onboard Serial port 2 and address is 2E8H.
Disabled	Disable onboard Serial port 2.

- Onboard Parallel port

The default value is 378H/IRQ7.

3BCH/IRQ7	Enable onboard LPT port and address is 3BCH/IRQ7.
378H/IRQ7	Enable onboard LPT port and address is 378H/IRQ7.
278H/IRQ5	Enable onboard LPT port and address is 278H/IRQ5.
Disabled	Disable onboard LPT port.

- Parallel port Mode

The default value is SPP.

SPP	Using Parallel port as Normal Printer Port.
EPP/SPP	Using Parallel port as Enhanced Parallel Port/ Normal Printer Port. ✱
ECP	Using Parallel port as Extended Capabilities Port. ✱
ECP/EPP	Using Parallel port as ECP & EPP mode/Enhanced Parallel Port. ✱

✱ As EPP/SPP Mode is selected, two options can be defined:

1. Parallel Port EPP type: EPP1.7
2. Parallel Port EPP type: EPP1.9

✱ As ECP,ECP/EPP Mode is selected, two options can be defined:

1. ECP Mode use DMA: 3
2. ECP Mode use DMA: 1

4.14. IDE HDD AUTO DETECTION

ROM PCI / ISA BIOS
 CMOS SETUP UTILITY
 AWARD SOFTWARE, INC.

STANDARD CMOS SETUP	INTEGRATED PERIPHERALS
BIOS FEATURES SETUP	SUPERVISOR PASSWORD
CHIPSET FEATURES SETUP	USER PASSWORD
POWER MANAGEMENT SETUP	IDE HDD AUTO DETECTION
PNP/PCI CONFIGURATION	HDD LOW LEVEL FORMAT
LOAD BIOS DEFAULTS	SAVE & EXIT SETUP
LOAD SETUP DEFAULTS	EXIT WITHOUT SAVING
ESC : Quit F10 : Save & Exit Setup	
↑ ↓ → ← : Select Item (Shift)F2 : Chang Color	
Auto-Configure HDD: Sector, Cylinder, Head...	

Figure 4.11: IDE HDD Auto Detection

Type "Y" will accept the H.D.D. parameter reported by BIOS.

Type "N" will keep the old H.D.D. parameter setup. If the hard disk cylinder NO. is over 1024, then the user can select LBA mode or LARGER mode for DOS partition LARGER than 528 MB.

4.15. HDD LOW LEVEL FORMAT

ROM PCI / ISA BIOS
 CMOS SETUP UTILITY
 AWARD SOFTWARE, INC.

STANDARD CMOS SETUP	INTEGRATED PERIPHERALS
BIOS FEATURES SETUP	SUPERVISOR PASSWORD
CHIPSET FEATURES SETUP	USER PASSWORD
POWER MANAGEMENT SETUP	IDE HDD AUTO DETECTION
PNP/PCI CONFIGURATION	HDD LOW LEVEL FORMAT
LOAD BIOS DEFAULTS	SAVE & EXIT SETUP
LOAD SETUP DEFAULTS	EXIT WITHOUT SAVING
ESC : Quit F10 : Save & Exit Setup	
↑ ↓ → ← : Select Item (Shift)F2 : Chang Color	
Hard Disk Low Level Format Utility	

Figure 4.12: HDD Low Level Format

HDD Low Level Format Utility:

In main manual: There are three options to choose:

- one is: SELECT DRIVE: "C" or "D".
- another one is: BAD TRACK LIST: User can auto, add, modify, delete, clear for bad track of HDD.
- the other one is : PREFORMAT: Lower Level Format HDD.

4.16. SAVE & EXIT SETUP

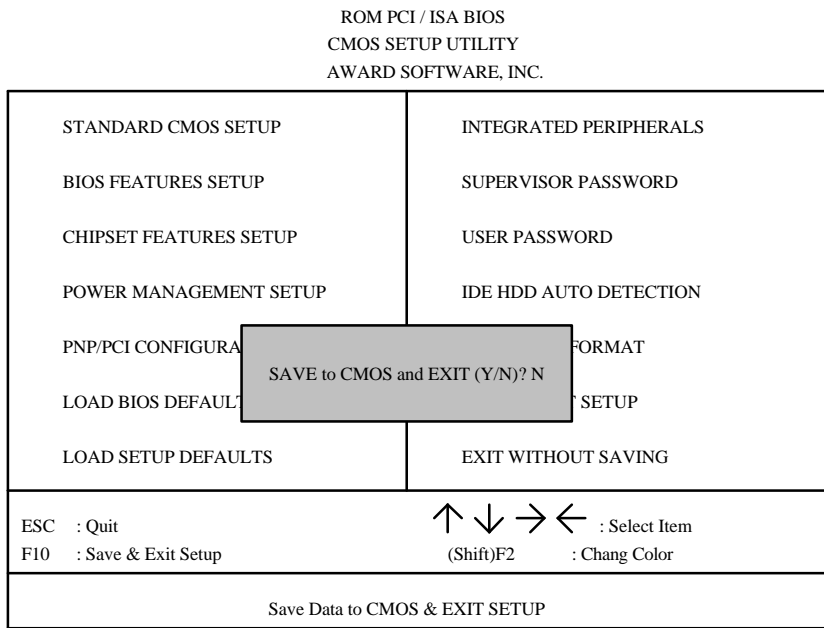

Figure 4.13: Save & Exit Setup

Type "Y" will quit the Setup Utility and save the user setup value to RTC CMOS SRAM.

Type "N" will return to Setup Utility.

4.17. EXIT WITHOUT SAVING

ROM PCI / ISA BIOS
 CMOS SETUP UTILITY
 AWARD SOFTWARE, INC.

STANDARD CMOS SETUP	INTEGRATED PERIPHERALS
BIOS FEATURES SETUP	SUPERVISOR PASSWORD
CHIPSET FEATURES SETUP	USER PASSWORD
POWER MANAGEMENT SETUP	IDE HDD AUTO DETECTION
PNP/PCI CONFIGURATION	FORMAT
LOAD BIOS DEFAULTS	FORMAT SETUP
LOAD SETUP DEFAULTS	EXIT WITHOUT SAVING
ESC : Quit F10 : Save & Exit Setup	
↑ ↓ → ← : Select Item (Shift)F2 : Chang Color	
Abandon all Datas & EXIT SETUP	

Figure 4.15: Exit Without Saving

Type "Y" will quit the Setup Utility without saving to RTC CMOS SRAM.

Type "N" will return to Setup Utility.

5.1.2. PCI - BUS SLOT PIN OUT

-12V	B01	A01	NC
NC	B02	A02	+12V
GND	B03	A03	NC
NC	B04	A04	NC
VCC	B05	A05	VCC
VCC	B06	A06	INTA#
INTB#	B07	A07	INTC#
INTD#	B08	A08	VCC
PST#1	B09	A09	NC
NC	B10	A10	VCC
PST#2	B11	A11	NC
GND	B12	A12	GND
GND	B13	A13	GND
NC	B14	A14	NC
GND	B15	A15	RST#
CLK	B16	A16	VCC
GND	B17	A17	GNT#
REQ#	B18	A18	GND
VCC	B19	A19	NC
AD_31	B20	A20	AD_30
AD_29	B21	A21	NC
GND	B22	A22	AD_28
AD_27	B23	A23	AD_26
AD_25	B24	A24	GND
NC	B25	A25	AD_24
CBE#3	B26	A26	JDSEL
AD_23	B27	A27	NC
GND	B28	A28	AD_22
AD_21	B29	A29	AD_20
AD_19	B30	A30	GND
NC	B31	A31	AD_18
AD_17	B32	A32	AD_16
CEB#2	B33	A33	NC
GND	B34	A34	FRAME#
IRDY#	B35	A35	GND
NC	B36	A36	TRDY#
DEVSEL#	B37	A37	GND
GND	B38	A38	STOP#
LOCK#	B39	A39	NC
PERR#	B40	A40	SDONE
NC	B41	A41	SBO#
SEERR#	B42	A42	GND
NC	B43	A43	PAR
CBE#1	B44	A44	AD_15
AD_14	B45	A45	NC
GND	B46	A46	AD_13
AD_12	B47	A47	AD_11
AD_10	B48	A48	GND
GND	B49	A49	AD_09
AD_08	B52	A52	CBE#0
AD_07	B53	A53	NC
NC	B54	A54	AD_06
AD_05	B55	A55	AD_04
AD_03	B56	A56	GND
GND	B57	A57	AD_02
AD_01	B58	A58	AD_00
VCC	B59	A59	VCC
NC	B60	A60	NC
VCC	B61	A61	VCC
VCC	B62	A62	VCC

5.2. I/O & MEMORY MAP

MEMORY MAP:	[0000000-009FFFFF]	System memory used by DOS and application program.
	[00A0000-00BFFFFF]	Display buffer memory for VGA/ EGA/CGA/MONOCHROME adapter.
	[00C0000-00DFFFFF]	Reserved for I/O device BIOS ROM or RAM buffer.
	[00E0000-00EFFFFF]	Reserved for PCI device ROM.
	[00F0000-00FFFFFF]	System BIOS ROM.
	[0100000-BFFFFFFF]	System extension memory.
I/O MAP:	[000-01F]	DMA controller.(Master)
	[020-021]	INTERRUPT controller.(Master)
	[022-023]	CHIPSET control registers I/O ports.
	[040-05F]	TIMER control registers.
	[060-06F]	KEYBOARD interface controller.(8042)
	[070-07F]	RTC ports & CMOS I/O ports.
	[080-09F]	DMA register.
	[0A0-0BF]	INTERRUPT controller.(Slave)
	[0C0-0DF]	DMA controller.(Slave)
	[0F0-0FF]	MATH COPROCESSOR
	[1F0-1F8]	HARD DISK controller.
	[278-27F]	PARALLEL port-2.
	[2B0-2DF]	GRAPHICS adapter controller.
	[2F8-2FF]	SERIAL port-2.
	[360-36F]	NETWORK ports.
	[378-37F]	PARALLEL port-1
	[3B0-3BF]	MONOCHROME & PRINTER adapter.
	[3C0-3CF]	EGA adapter.
	[3D0-3DF]	CGA adapter.
	[3F0-3F7]	FLOPPY DISK controller.
	[3F8-3FF]	SERIAL port-1.

5.3. TIMER & DMA CHANNELS MAP

TIMER MAP: TIMER Channel-0 System timer interrupt
 TIMER Channel-1 DRAM REFRESH request
 TIMER Channel-2 SPEAKER tone generator

DMA CHANNELS: DMA Channel-0 Available
 DMA Channel-1 IBM SDLC
 DMA Channel-2 FLOPPY DISK adapter
 DMA Channel-3 Available
 DMA Channel-4 Cascade for DMA controller 1
 DMA Channel-5 Available
 DMA Channel-6 Available
 DMA Channel-7 Available

5.4. INTERRUPT MAP

NMI: Parity check error

IRQ (H/W):

- 0 System TIMER interrupt from TIMER-0
- 1 KEYBOARD output buffer full
- 2 Cascade for IRQ 8-15
- 3 SERIAL port 2
- 4 SERIAL port 1
- 5 PARALLEL port 2
- 6 FLOPPY DISK adapter
- 7 PARALLEL port 1
- 8 RTC clock
- 9 Available
- 10 Available
- 11 Available
- 12 PS/2 Mouse
- 13 MATH coprocessor
- 14 HARD DISK adapter
- 15 Available

5.5. RTC & CMOS RAM MAP

RTC & CMOS:	00	Seconds
	01	Second alarm
	02	Minutes
	03	Minutes alarm
	04	Hours
	05	Hours alarm
	06	Day of week
	07	Day of month
	08	Month
	09	Year
	0A	Status register A
	0B	Status register B
	0C	Status register C
	0D	Status register D
	0E	Diagnostic status byte
	0F	Shutdown byte
	10	FLOPPY DISK drive type byte
	11	Reserve
	12	HARD DISK type byte
	13	Reserve
	14	Equipment byte
	15	Base memory low byte
	16	Base memory high byte
	17	Extension memory low byte
	18	Extension memory high byte
	19-2d	
	2E-2F	
	30	Reserved for extension memory low byte
	31	Reserved for extension memory high byte
	32	DATE CENTURY byte
	33	INFORMATION FLAG
	34-3F	Reserve
	40-7f	Reserved for CHIPSET SETTING DATA

APPENDIX A: POST MESSAGE

When the BIOS encounters an error that requires the user to correct something, either a beep code will sound or a message will be displayed in a box in the middle of the screen and the message PRESS F1 TO CONTINUE, CTRL-ALT-ESC OR DEL TO ENTER SETUP will be shown in the information box at the bottom.

- POST BEEP

Currently there is only one beep code in BIOS. This code indicates that a video error has occurred and the BIOS cannot initialize the video screen to display any additional information. This beep code consists of a single long beep followed by two short beeps.

- ERROR MESSAGE

Once or more of the following messages may be displayed if the BIOS detects an error during the POST. This list includes message for both the ISA and the EISA BIOS.

- ☒ CMOS BATTERY HAS FAILED

CMOS battery is no longer functional. It should be replaced.

- ☒ CMOS CHECKSUM ERROR

Checksum of CMOS is incorrect. This can indicate that CMOS has become corrupt. This error may have been caused by a weak battery. Check the battery and replace if necessary.

- ☒ DISK BOOT FAILURE, INSERT SYSTEM DISK AND PRESS ENTER

No boot device was found. Insert a system disk into Drive A: and press <Enter>. If you assumed the system would boot from the hard drive, make sure the controller is inserted correctly and all cables are properly attached. Also be sure the disk is formatted as a boot device. Then reboot the system.

- ☒ DISKETTE DRIVES OR TYPES MISMATCH ERROR - RUN SETUP

Type of diskette drive installed in the system is different from the CMOS definition. Run Setup to re-configure the drive type correctly.

⊗ DISPLAY SWITCH IS SET INCORRECTLY

Display switch on the motherboard can be set to either monochrome or color. This indicates the switch is set to a different setting than indicated in Setup. Determine which setting is correct, and then either turn off the system and change the jumper, or enter Setup and change the VIDEO selection.

⊗ DISPLAY TYPE HAS CHANGED SINCE LAST BOOT

Since last powering off the system, the display adapter has been changed. You must configure the system for the new display type.

⊗ EISA Configuration Checksum Error

PLEASE RUN EISA CONFIGURATION UTILITY

The EISA non-volatile RAM checksum is incorrect or cannot correctly read the EISA slot. This can indicate either the EISA non-volatile memory has become corrupted or the slot has been configured incorrectly. Also be sure the card is installed firmly in the slot.

⊗ EISA Configuration Is Not Complete

PLEASE RUN EISA CONFIGURATION UTILITY

The slot configuration information stored in the EISA non-volatile memory is incomplete.

☞ When either of these errors appear, the system will boot in ISA mode, which allows you to run the EISA Configuration Utility.

⊗ ERROR ENCOUNTERED INITIALIZING HARD DRIVE

Hard drive cannot be initialized. Be sure the adapter is installed correctly and all cables are correctly and firmly attached. Also be sure the correct hard drive type is selected in Setup.

⊗ ERROR INITIALIZING HARD DISK CONTROLLER

Cannot initialize controller. Make sure the cord is correctly and firmly installed in the bus. Be sure the correct hard drive type is selected in Setup. Also check to see if any jumper needs to be set correctly in the hard drive.

⊗ FLOPPY DISK CNTRLR ERROR OR NO CNTRLR PRESENT

Cannot find or initialize the floppy drive controller. Make sure the controller is installed correctly and firmly. If there are no floppy drives installed, be sure the Diskette Drive selection in Setup is set to NONE.

⊗ Invalid EISA Configuration

PLEASE RUN EISA CONFIGURATION UTILITY

The non-volatile memory containing EISA configuration information was programmed incorrectly or has become corrupted. Re-run EISA configuration utility to correctly program the memory.

☞ When this error appears, the system will boot in ISA mode, which allows you to run the EISA Configuration Utility.

⊗ KEYBOARD ERROR OR NO KEYBOARD PRESENT

Cannot initialize the keyboard. Make sure the keyboard is attached correctly and no keys are being pressed during the boot.

If you are purposely configuring the system without a keyboard, set the error halt condition in Setup to HALT ON ALL, BUT KEYBOARD. This will cause the BIOS to ignore the missing keyboard and continue the boot.

⊗ Memory Address Error at ...

Indicates a memory address error at a specific location. You can use this location along with the memory map for your system to find and replace the bad memory chips.

⊗ Memory parity Error at ...

Indicates a memory parity error at a specific location. You can use this location along with the memory map for your system to find and replace the bad memory chips.

⊗ MEMORY SIZE HAS CHANGED SINCE LAST BOOT

Memory has been added or removed since the last boot. In EISA mode, use Configuration Utility to re-configure the memory configuration. In ISA mode, enter Setup and enter the new memory size in the memory fields.

☒ Memory Verify Error at ...

Indicates an error verifying a value already written to memory. Use the location along with your system's memory map to locate the bad chip.

☒ OFFENDING ADDRESS NOT FOUND

This message is used in conjunction with the I/O CHANNEL CHECK and RAM PARITY ERROR messages when the segment that has caused the problem cannot be isolated.

☒ OFFENDING SEGMENT:

This message is used in conjunction with the I/O CHANNEL CHECK and RAM PARITY ERROR messages when the segment that has caused the problem has been isolated.

☒ PRESS A KEY TO REBOOT

This will be displayed at the bottom screen when an error occurs that requires you to reboot. Press any key and the system will reboot.

☒ PRESS F1 TO DISABLE NMI, F2 TO REBOOT

When BIOS detects a Non-maskable Interrupt condition during boot, this will allow you to disable the NMI and continue to boot. Or you can reboot the system, which will enable the NMI.

☒ RAM PARITY ERROR - CHECKING FOR SEGMENT ...

Indicates a parity error in Random Access Memory.

☒ Should Be Empty But EISA Board Found

PLEASE RUN EISA CONFIGURATION UTILITY

A valid board ID was found in a slot that was configured as having no board ID.

☞ When this error appears, the system will boot in ISA mode, which allows you to run the EISA Configuration Utility.

☒ Should Have EISA Board But Not Found

PLEASE RUN EISA CONFIGURATION UTILITY

The board installed is not responding to the ID request, or no board ID has been found in the indicated slot.

☞ When this error appears, the system will boot in ISA mode, which allows you to run the EISA Configuration Utility.

☒ Slot Not Empty

Indicates that a slot designated as empty by the EISA Configuration Utility actually contains a board.

☞ When this error appears, the system will boot in ISA mode, which allows you to run the EISA Configuration Utility.

☒ SYSTEM HALTED, (CTRL-ALT-DEL) TO REBOOT ...

Indicates the present boot attempt has been aborted and the system must be rebooted. Press and hold down the CTRL and ALT keys and press DEL.

☒ Wrong Board In Slot

PLEASE RUN EISA CONFIGURATION UTILITY

The board ID does not match the ID stored in the EISA non-volatile memory.

☞ When this error appears, the system will boot in ISA mode, which allows you to run the EISA Configuration Utility.

APPENDIX B: POST CODES

☞ EISA POST codes are typically output to port address 300h. ISA POST codes are typically output to port address 80h.

POST	Name	Description
C0	Turn Off Chipset Cache	OEM Specific-Cache control.
1	Processor Test 1	Processor Status (1 FLAGS) Verification. Test the following processor status flags carry, zero, sign, overflow, The BIOS will set each of these flags, verify they are set, then turn each flag off and verify it is off.
2	Processor Test 2	Read/Write/Verify all CPU registers except SS, SP, and BP with data pattern FF and 00.
3	Initialize Chips	Disable NMI, PIE, AIE, UEI, SQWV. Disable video, parity checking, DMA. Reset math coprocessor. Clear all page registers, CMOS shutdown byte. Initialize timer 0, 1, and 2, including set EISA timer to a known state. Initialize DMA controllers 0 and 1. Initialize interrupt controllers 0 and 1. Initialize EISA extended registers.
4	Test Memory Refresh Toggle	RAM must be periodically refreshed in order to keep the memory from decaying. This function assures that the memory refresh function is working properly.
5	Blank video, Initialize keyboard	Keyboard controller initialization.
6	Reserved	
7	Test CMOS Interface and Battery Status	Verifies CMOS is working correctly, detects bad battery.
BE	Chipset Default Initialization	Program chipset registers with power on BIOS defaults.
C1	Memory presence test	OEM Specific-Test to size on-board memory.
C5	Early Shadow	OEM Specific-Early Shadow enable for fast boot.
C6	Cache presence test	External cache size detection.
8	Setup low memory	Early chip set initialization. Memory presence test. OEM chip set routines. Clear low 64 K of memory. Test first 64 K memory.

9	Early Cache Initialization	Cyrix CPU initialization. Cache initialization.
A	Setup Interrupt Vector Table	Initialize first 120 interrupt vectors with SPURIOUS_INT-HDLR and initialize INT 00h-1Fh according to INT_TBL.
B	Test CMOS RAM Checksum	Test CMOS RAM Checksum, if bad, or insert key pressed, load defaults.
C	Initialize keyboard	Detect type of keyboard controller (optional). Set NUM_LOCK status.
D	Initialize Video Interface	Detect CPU clock. Read CMOS location 14h to find out type of video in use. Detect and Initialize Video Adapter.
E	Test Video Memory	Test video memory, write sign-on message to screen. Setup shadow RAM - Enable shadow according to Setup.
F	Test DMA Controller 0	BIOS checksum test. Keyboard detect and initialization.
10	Test DMA Controller 1	
11	Test DMA Page registers	Test DMA Page Registers.
12-13	Reserved	
14	Test Timer Counter 2	Test 8254 Timer 0 Counter 2.
15	Test 8259-1 Mask Bits	Verify 8259 Channel 1 masked interrupts by alternately turning off and on the interrupt lines.
16	Test 8259-2 Mask Bits	Verify 8259 Channel 2 masked interrupts by alternately turning off and on the interrupt lines.
17	Test Stuck 8259's Interrupt Bits	Turn off interrupts then verify no interrupt mask register is on.
18	Test 8259 Interrupt Functionality	Force an interrupt and verify the interrupt occurred.
19	Test Stuck NMI Bits (Parity/IO Check)	Verify NMI can be cleared.
1A		Display CPU clock.
1B-1E	Reserved	
1F	Set EISA Mode	If EISA non-volatile memory checksum is good, execute EISA initialization. If not, execute ISA tests and clear EISA mode flag. Test EISA Configuration Memory Integrity (checksum & communication interface).
20	Enable Slot 0	Initialize slot 0 (System Board).
21-2F	Enable Slots 1-15	Initialize slot 1 through 15.

Appendix B: Post Codes

30	Size Base and Extended Memory	Size base memory from 256 K to 640 K extended memory above 1 MB.
31	Test Base and Extended Memory	Test base memory from 256 K to 640 K and extended memory above 1 MB using various patterns. ☞ This will be skipped in EISA mode and can be "skipped" with ESC key in ISA mode.
32	Test EISA Extended Memory	If EISA Mode flag is set then test EISA memory found in slots initialization. ☞ This will be skipped in ISA mode and can be "skipped" with ESC key in EISA mode.
33-3B	Reserved	
3C	Setup Enabled	
3D	Initialize & Install Mouse	Detect if mouse is present, initialize mouse, install interrupt vectors.
3E	Setup Cache Controller	Initialize cache controller.
3F	Reserved	
BF	Chipset Initialization	Program chipset registers with Setup values.
40		Display virus protest disable or enable.
41	Initialize Floppy Drive & Controller	Initialize floppy disk drive controller and any drives.
42	Initialize Hard Drive & Controller	Initialize hard drive controller and any drives.
43	Detect & Initialize Serial/Parallel Ports	Initialize any serial and parallel ports (also game port).
44	Reserved	
45	Detect & Initialize Math Coprocessor	Initialize math coprocessor.
46	Reserved	
47	Reserved	
48-4D	Reserved	
4E	Manufacturing POST Loop or Display Messages	Reboot if Manufacturing POST Loop pin is set. Otherwise display any messages (i.e., any non-fatal errors that were detected during POST) and enter Setup.
4F	Security Check	Ask password security (optional).
50	Write CMOS	Write all CMOS values back to RAM and clear screen.
51	Pre-boot Enable	Enable parity checker. Enable NMI, Enable cache before boot.
52	Initialize Option ROMs	Initialize any option ROMs present from C8000h to EFFFFh. ☞ When FSCAN option is enabled, will initialize from C8000h to F7FFFh.
53	Initialize Time	Initialize time value in 40h: BIOS area.

	Value	
60	Setup Virus Protect	Setup virus protect according to Setup
61	Set Boot Speed	Set system speed for boot
62	Setup NumLock	Setup NumLock status according to Setup
63	Boot Attempt	Set low stack. Boot via INT 19h.
B0	Spurious	If interrupt occurs in protected mode.
B1	Unclaimed NMI	If unmasked NMI occurs, display Press F1 to disable NMI, F2 reboot.
E1-EF	Setup Pages	E1 - Page 1, E2 - Page 2, etc.
FF	Boot	

APPENDIX C: BIOS DEFAULT DRIVE TABLE

Type	Size (MB)	Cylinders	Heads	Sectors	Write / Precomp	Land Zone	Example Model
1	10 MB	306	4	17	128	305	TEAC SD510 MMI 112, 5412
2	20 MB	615	4	17	300	615	Seagate ST225, ST4026
3	31 MB	615	6	17	300	615	
4	62 MB	940	8	17	512	940	
5	47 MB	940	6	17	512	940	
6	20 MB	615	4	17	65535	615	Seagate ST125 Tandon TM262
7	31 MB	462	8	17	256	511	
8	30 MB	733	5	17	65535	733	Tandon TM703
9	112 MB	900	15	17	65535	901	
10	20 MB	820	3	17	65535	820	
11	35 MB	855	5	17	65535	855	
12	50 MB	855	7	17	65535	855	
13	20 MB	306	8	17	128	319	Disctron526, MMI M125
14	43 MB	733	7	17	65535	733	
16	20 MB	612	4	17	0	663	Microscience HH725 Syquest3250, 3425
17	41 MB	977	5	17	300	977	
18	57 MB	977	7	17	65535	977	
19	60 MB	1024	7	17	512	1023	
20	30 MB	733	5	17	300	732	
21	43 MB	733	7	17	300	732	
22	30 MB	733	5	17	300	733	Seagate ST4038
23	10 MB	306	4	17	0	336	
24	54 MB	925	7	17	0	925	Seagate ST4051
25	69 MB	925	9	17	65535	925	Seagate ST4096
26	44 MB	754	7	17	754	754	Maxtor2085
27	69 MB	754	11	17	65535	754	Maxtor2140, Priam S14
28	41 MB	699	7	17	256	699	Maxtor2190, Priam S19
29	68 MB	823	10	17	65535	823	Maxtor1085 Micropolis1325
30	53 MB	918	7	17	918	918	Maxtor1105, 1120, 4780
31	94 MB	1024	11	17	65535	1024	Maxtor1170
32	128 MB	1024	15	17	65535	1024	CDC9415
33	43 MB	1024	5	17	1024	1024	
34	10 MB	612	2	17	128	612	
35	77 MB	1024	9	17	65535	1024	

36	68 MB	1024	8	17	512	1024	
37	41 MB	615	8	17	128	615	
38	25 MB	987	3	17	987	987	
39	57 MB	987	7	17	987	987	Maxtor1140, 4380
40	41 MB	820	6	17	820	820	Seagate ST251
41	41 MB	977	5	17	977	977	Seagate ST4053 Miniscribe3053/ 6053
42	41 MB	981	5	17	981	981	Miniscribe3053/ 6053 RLL
43	48 MB	830	7	17	512	830	Miniscribe 3650
44	69 MB	830	10	17	65535	830	Miniscribe 3650 RLL
45	114 MB	917	15	17	65535	918	Conner CP3104
46	152 MB	1224	15	17	65535	1223	Conner CP3204
User							

APPENDIX D: PROBLEM SHEET

1. Customer Data

Name
Address
Tel. No.
Fax. No.
Purchase Date

2. Mainboard Data

Model NO. GA-
Serial No. Rev. No.

3. System Configuration

CPU Type:
CPU Brand:
CPU Speed:
DRAM Type: 1 2 4 8 16 32 MB
DRAM Speed: 80 70 60 ns
DRAM Total Size: MB
DRAM Brand:
SRAM Size: 64KB 128 KB 256 KB 512 KB
SRAM Part No. TAG: DATA:
Video Card:
Video Chip or Brand:
Floppy Drive A Capacity & Brand:
Floppy Drive B Capacity & Brand:
Storage Controller Type MFM RLL IDE EDSI SCSI
Hard Drive C Brand & Type:
Hard Drive D Brand & Type:
LAN Controller Type:
LAN Card Brand & Model:
Serial / Parallel Chip Brand & Model:
Mouse Brand & Model:
O.S. DOS OS/2 NETWARE UNIX / XENIX Ver.:

4. AUTOEXEC.BAT & CONFIG.SYS File:

5. Problem Description:

R-11-04-061022