

TriGem Micro-ATX Motherboard (FLORIDA-TG)

Table of Contents

I. Introduction

1. Generation Description	2
2. Function Block Diagram	4

II. System Overview

1. Major Units	5
2. Upgradeability	6
2-1. Processor	6
2-2. Memory	6
2-3. BIOS	7
2-4. Expansion Slot	7
2-5. Advanced Configuration and Power Interface (ACPI)	8
2-6. Manufacturing Options	8

III. Jumper & Connector Description

1. Motherboard Jumper Setting	9
1-1. Selection for Processor CPU Clock	9
1-2. Other functionality	9
1-3. AGP graphics device function	10
1-4. OEM/ODM selector	10
2. Motherboard Connector Description	11
2-1. Motherboard Internal Connector	11
2-2. Motherboard External I/O Port	14
3. Joystick & USB daughter board	14

I. Introduction

The *Florida-TG* Micro ATX motherboard offers a time to market consumer and corporate desktop solution featuring the Intel Celeron PPGA processor with 66MHz front side bus and the Intel 440LX AGP sets in a Micro ATX low profile motherboards. In addition, the integrated graphics components have been upgraded with the AGP graphics controller and 4 or 8MB of SGRAM.

The *Florida-TG* motherboard was designed to be highly minimized system cost. In this effort a smaller form factor, Micro-ATX, gives the greater space economy and more affordable systems. Integrating AGP graphics controller and SGRAM, as well as PCI audio solution with AC97 Codec onto the motherboard eliminates the need for more expensive graphic and audio add-in cards. The end result is a system platform with a primary component level of integration with translates into affordable solution for entry level users.

1. General description

- ❑ Motherboard
 - Small PCB size in the Micro ATX form factor (ATX V1.2 form factor)
 - 227mm * 244mm * 1.6t (4 Layers)
- ❑ Processor
 - Intel Socket-370 (370pin PPGA Socket)
 - Intel Celeron 300A/333/366/400MHz processor support
- ❑ Main Chipset
 - AGPsets PCI/AGP Controller : Intel 440LX
 - PCI bus mastering controller, and Power management interface : Intel PIIX4e
 - Graphics : ATi RAGE Pro Turbo with 4 or 8 MB SGRAM
 - Audio : Crystal CS4280 with Ac97 Codec(CS4297)
 - Super I/O : ITE8673
 - DC-DC Converter : SC1164
 - Clock : ICS9148BF (66MHz host clock support)
- ❑ Memory Configuration
 - System Memory
 - Two banks of 3.3V EDO/SDRAM (168pin unbuffered DIMM) with max 256MB
 - EDO/SDRAM operation in 66MHz front side bus
 - Flash Memory : Programmable 2MB Flash memory
- ❑ I/O Feature
 - Integrated standard I/O functions in the rear side
 - One multi-mode parallel port
 - One FIFO serial ports and optional port by header type
 - PS/2 styles keyboard and mouse port
 - One USB port
 - Three audio jack for Line input, Speaker output and MIC input
 - Integrated standard I/O functions in the front side
 - One Joystick port
 - One USB port
- ❑ Audio Subsystem
 - Crystal CS4280 PCI audio controller with fully DOS Games compatibility via PC/PCI, DDMA support
 - Compatible with sound blaster, sound blaster pro, and window sound system
 - Enhanced Stereo full duplex operation
 - Advanced MPC3-compatible input and output mixer
 - Joystick port and MPU-401 compatible MIDI interface
 - PC97 and PC98 compliance(and compliance with preliminary PC99)

□ Graphics Subsystem

- General features
 - First graphics accelerator to support AGP 2X mode with Sideband Addressing and AGP Texturing (Execute mode) to realize all the benefits of AGP
 - Superior 3D performance achieved through a floating point setup engine rated at 1.2 million triangles/sec
 - 100MHz SGRAM support for maximum 2D and 3D performance
 - Integrated 230MHz DAC allows 85Hz refresh at 1600x1200 resolutions
 - Flexible graphics memory configuration : 4MB or 8MB SGRAM(Manufacture option)
 - Integrates superior video features, including filtered scaling of 720 pixel DVD content and MPEG-2 motion compensation for software DVD
 - Highly integrated 64 bit graphics accelerator with superior support for 3D and motion video, making it ideal for multimedia PCs
 - Ati Rage Pro Turbo delivers superior 3D acceleration and comprehensive 3D support including support for true color (32bpp) rendering, a triangle set-up engine, single-pass trilinear filtering, six perspective correct texturing modes, video texturing.
- 3D Acceleration
 - Hidden surface removal using 16-bit z-buffering
 - Full support for Direct3D texture lighting
 - Dithering support in 16bpp for near 24bpp quality in less memory

2. Function Block Diagram

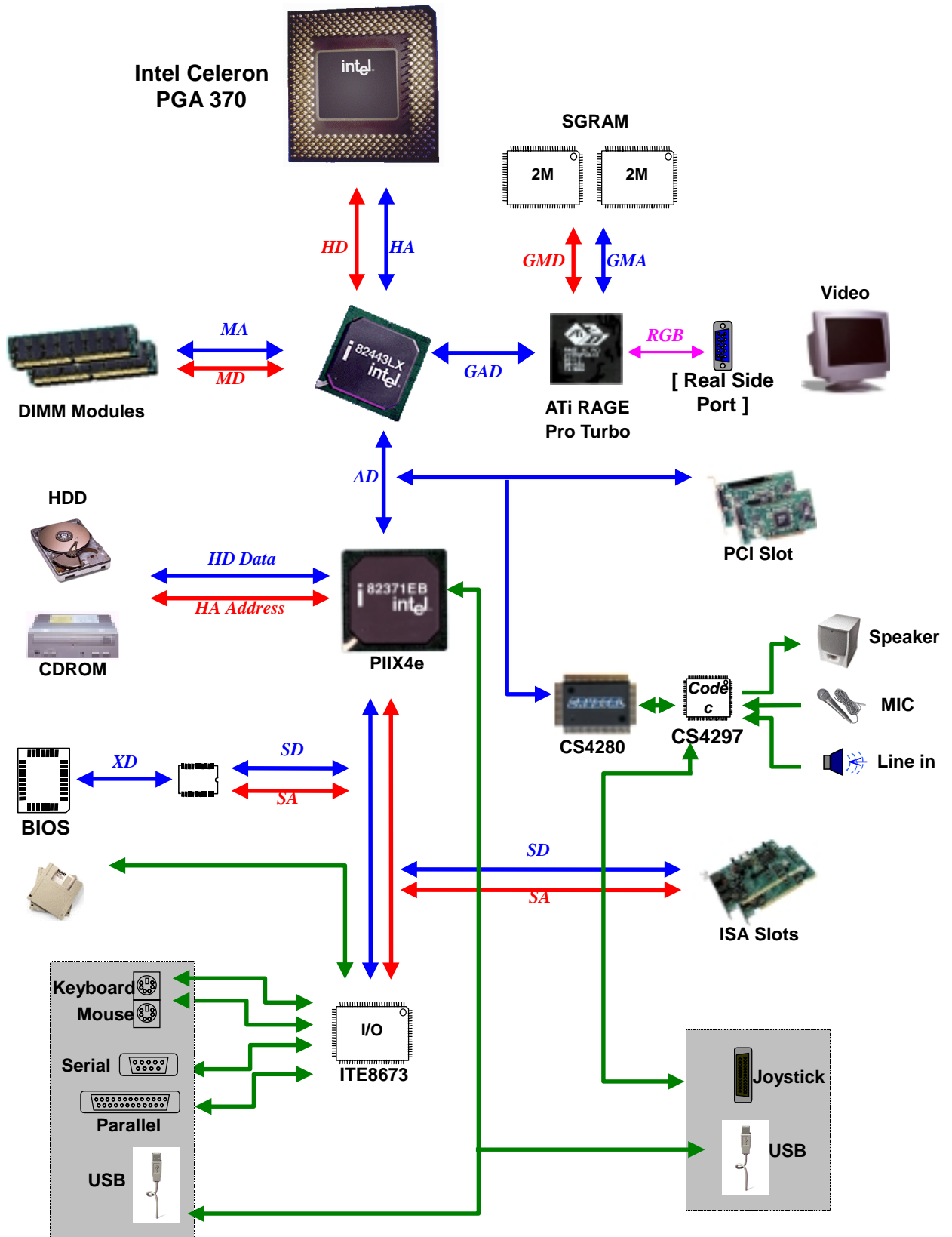

II. System Overview

1. Major Units

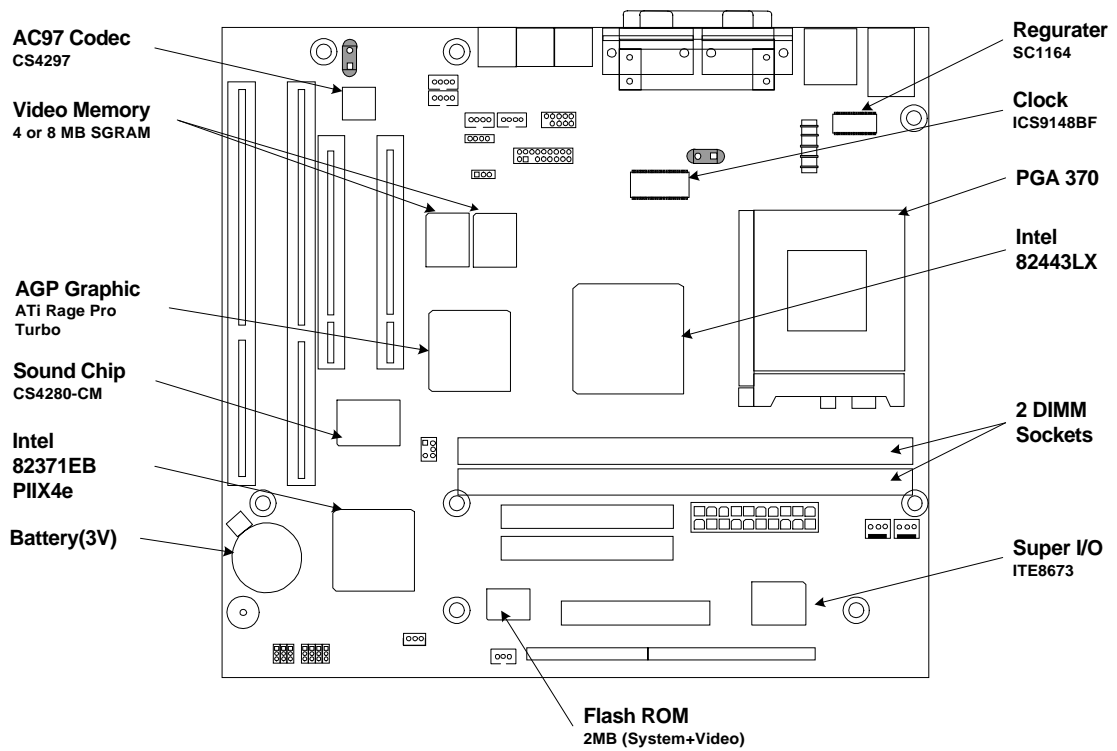

2. Upgradeability

2-1. Processor

FLORIDA-TG motherboard provides the 370pin PGA370 socket that is not backward compatible with ZIF socket-7 processors. The Processor's VID pin automatically programs the voltage regulator on the motherboard to the required processor voltage. The motherboard supports processors that run internally at 300/333/366/400 MHz.

- Supported Intel Celeron Processors (PPGA Socket Type)
 - Intel : Celeron 300MHz
 - : Celeron 333MHz
 - : Celeron 366MHz
 - : Celeron 400MHz

2-2. Memory

The motherboard has two, dual inline memory module (DIMM), minimum 16MB to maximum 256MB memory size. The BIOS can automatically detect the memory type, size, and speed through SMBUS interface between the core chipset and DIMM module.

The motherboard supports the following memory features

- 3.3V and unbuffered 168-pin DIMM

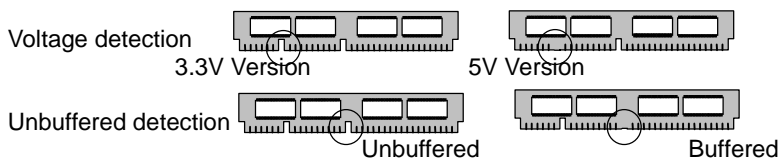

- 66MHz and 100MHz unbuffered SDRAM, and also EDO DRAM
- Non-ECC memory and ECC memory support
- Single or double-sided DIMM with the following types

DIMM size	Non-ECC memory	ECC memory
16MB	2Mbit * 64bit	2Mbit * 72bit
32MB	4Mbit * 64bit	4Mbit * 72bit
64MB	8Mbit * 64bit	8Mbit * 72bit
128MB	16Mbit * 64bit	16Mbit * 72bit

2-3 BIOS

The motherboard uses a TriGem-AMI BIOS, which is stored in flash memory and can be upgraded using a disk-based program. A new version of the BIOS can be upgraded from a diskette using the Flash Memory Update utility.

Flash memory organization

Address (Hex)	Size	Functional description
FFFF0000 - FFFFFFFF	64KB	Boot block
FFFA0000 - FFFFFFFF	256KB	Main BIOS block
FF9F0000 - FFF9FFFF	8KB	Used by BIOS (Event logging)
FFF9E000 - FFF9EFFF	8KB	OEM logo or can flash area
FFF9C000 - FFF9DFFF	16KB	DMI configuration data, PnP,
FFF90000 - FFF9BFFF	96KB	Fault tolerant storage
FFF80000 - FFF8FFFF	64KB	Fault tolerant backup block

On-board device management

The BIOS can manage the devices on the motherboard over the CMOS setup menu. However the corresponding jumper as described Jumper setting section later can disable the built-in AGP graphics controller.

Device	Description	CMOS setup menu	Default value
Internal Cache	Celeron PPGA Processor	Enable / Disable	Enabled
PS/2 Mouse	Intel 82371EB (PIIX4e)	Enable / Disable	Enabled
USB Function	Intel 82371EB (PIIX4e)	Enable / Disable	Enabled
On board Sound	CS4280 with CS4297 Codec	Enable / Disable	Enabled
On board FDC	Super I/O (ITE8673)	Auto / Enable / Disable	Auto
On board serial	Super I/O (ITE8673)	Auto / 3F8 / 2F8 / 3E8 / 2E8	Auto
On board parallel	Super I/O (ITE8673)	Auto / Disable / 378 / 278 / 3BC	Auto
On board IDE	Intel 82371EB (PIIX4e)	Disable / Primary / Secondary / Both	Both

2-4. Expansion Slot

The motherboard support ISA, PCI and AGP function. ISA and PCI functions are extended to the additional slot with two ISA and two PCI, and AGP function is designed in the motherboard with AGP graphics controller.

PCI configuration space map

Bus number	Device number	Function number	Device
00	00	00	Intel 82443LX
00	01	00	Intel 82371EB (PIIX4e)
00	07	00	PCI/ISA bridge (PIIX4e)
00	07	01	IDE bus master (PIIX4e)
00	07	02	USB (PIIX4e)
00	07	03	Power management (PIIX4e)
01	00	00	ATi Rage Pro Turbo graphic controller (AGP)
00	13	00	PCI slot1
00	12	00	PCI slot2

❑ PCI interrupt & master number routing map

Intel 82371EB (PIIX4e) PCI/ISA bridge has four programmable interrupt request input signals. Any PCI interrupt source connects to one of these interrupts signals and assigned to the free proper interrupt number by PnP BIOS.

SB INT signals	First PCI slot	Second PCI slot	AGP * graphics	PIIX4e USB device
PIRQA	INTA	INTB	INTA	INTA
PIRQB	INTB	INTC		
PIRQC	INTC	INTD		
PIRQD	INTD	INTA		
Master	REQ0	REQ1		
IDSEL	AD30	AD29	AD18	

 Note
Also AGP graphics controller does not use any PCI interrupt in the *Florida-TG* motherboard, because the interrupt function of AGP graphics controller was designed to disabled status. For more information, please contact the technical support team.

2-5. Advanced Configuration and Power Interface (ACPI)

The motherboard and system BIOS support the ACPI that requires an ACPI-aware operating system such as Windows-NT 5.0 or Windows 98. ACPI feature include

- Plug and play and APM functionality normally contained in the BIOS
- Power management control of individual devices : add-in cards, hard disk drives, USB devices, and Video
- A soft-off feature that enables operating system to power off the computer
- Support for multiple wakeup events
- Indication LED for normal mode (Green), standby mode (Blinking Green), and suspend mode (Blinking Green) but this function is dependent on the LED logic.

❑ Wakeup devices and events

Wakeup device	Wakeup events and functionality
Power switch	Wakeup from Power-off status and power-off function
LAN	Wakeup from power-off status
Modem	Wakeup from power-off status
Thermal event	Wakeup from power-off status
Sleep button	Wakeup from power-off status and go to suspend mode (option)

2-6. Manufacturing Options

The motherboard has several manufacturing options according to OEM/ODM requirement. Make sure that these options can be applied in the assembly stage, and it's impossible to upgrade or change in the customer field.

Option items	Selectable functionality	Feature changes
Joystick port	Front side / Rear side	Use additional board or not
USB port	Front side / Rear side	Use additional board or not
Super I/O	ITE8673 / ITE8693	Include LM79
Graphics controller	Rage Pro Turbo	AGP mode (2x)
Graphics memory	4MB / 8MB(Option)	Two SGRAM configuration

III. Jumper & Connector Description

1. Motherboard Jumper Setting

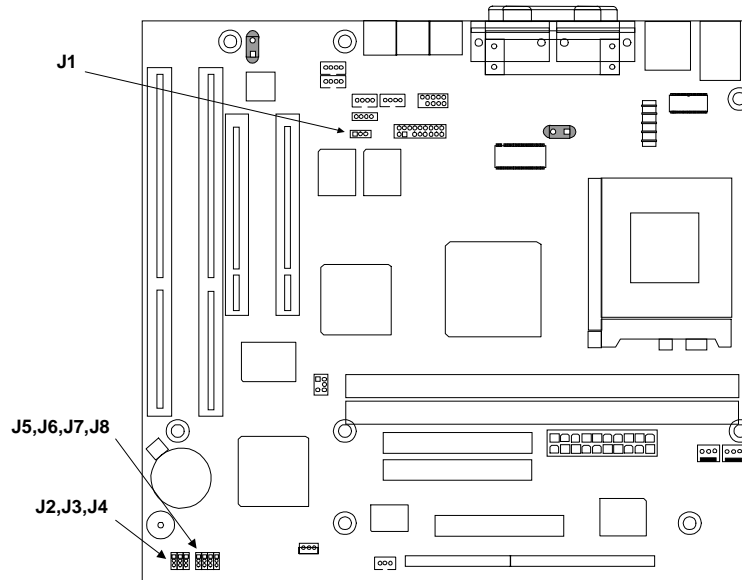

1-1. Selection for Processor CPU Clock

 Intel Celeron PPGA Processor is auto set the core to bus frequency ratio.

1-2. Other functionality

DIP Switch	Function	2-3	1-2(Default)
J5	CMOS RAM function	Clear CMOS RAM	Enable write/save
J6	Password function	Clear password	Enable password
J7	CMOS setup function	Disable to edit CMOS contents	Enable to edit CMOS contents
J8	FDD write protect	Disable to write data to Floppy disk	Enable to write data to Floppy disk

1-3. AGP graphics device function

This jumper does set the functionality of the built-in AGP graphics controller	
J1	AGP device functionality
1-2	Disable AGP graphics controller built in the motherboard
2-3 (default)	Enable AGP graphics controller built in the motherboard

1-4. OEM/ODM selector

These jumpers (J2, J3 & J4) will be optional parts for the OEM/ODM logo message selector.

2. I/O Header Connector Description

2-1. Motherboard Internal Connector

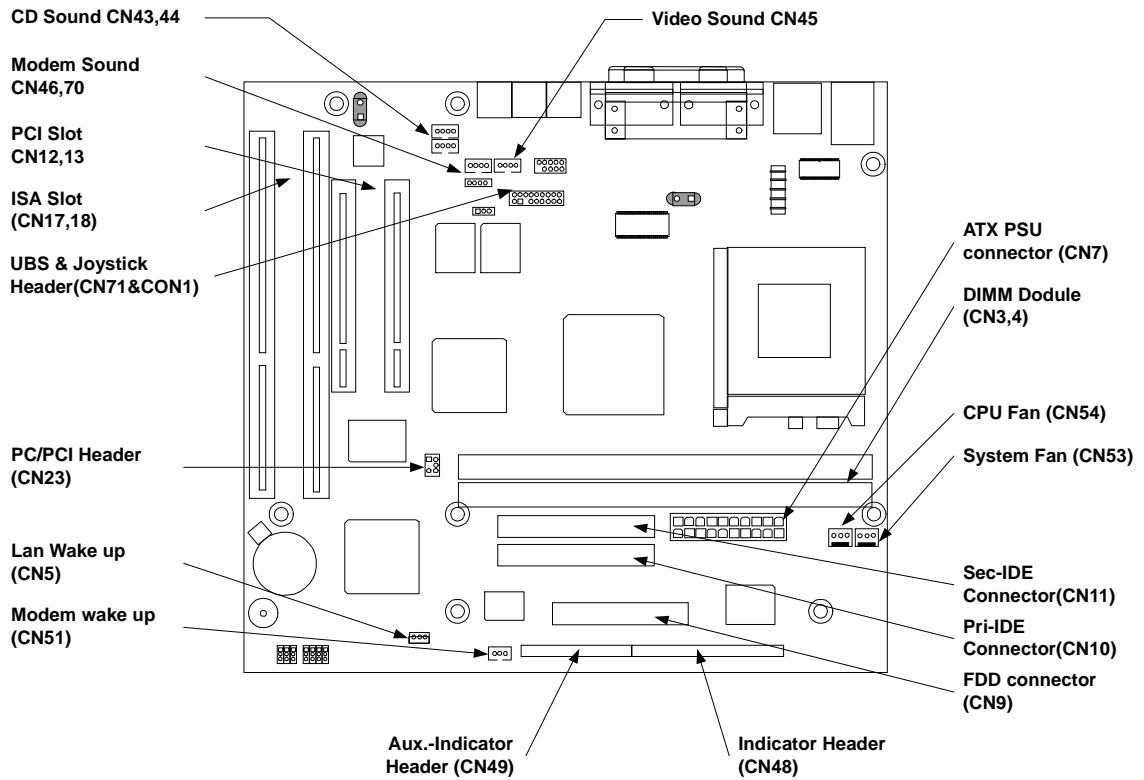

- ❑ CPU FAN connector (CN54)



Pin number	Signal description
1	GND
2	FAN power
3	Tachometer (speed)

- ❑ System Chassis FAN connector (CN53)



Pin number	Signal description
1	GND
2	FAN control
3	Tachometer (Speed)

□ PC/PCI connector (CN23)



Pin	Signal description	Pin	Signal description
1	/PCGNTA	4	/PCREQA
2	GND	5	N.C
3	Key	6	SER_IRQ

□ Joystick & USB connector (CON1, CN71)

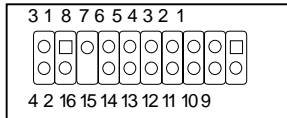

Pin	Signal description	Pin	Signal description
1	VCC	9	VCC
2	GD(4)	10	GD(6)
3	GD(0)	11	GD(2)
4	GND	12	MIDI OUT
5	GND	13	GD(3)
6	GD(1)	14	GD(7)
7	GD(5)	15	MIDI IN
8	VCC	16	Key
1	GND	3	Positive DATA
2	Negative DATA	4	VCC

□ Video Sound (CN45)



Pin	Signal description	Pin	Signal description
1	Left Sound	3	GND
2	GND	4	Right Sound

□ Modem Sound (CN46, CN70)



CN46

Pin	Signal description	Pin	Signal description
1	MIC	4	GND
2	GND	5	MONO IN
3	MONO OUT		



CN70

Pin	Signal description	Pin	Signal description
1	MONO IN	3	GND
2	GND	4	MIC

□ CD Sound (CN43, CN44)



ATAPI CD (CN43)

Pin	Signal description	Pin	Signal description
1	Left Sound	3	GND
2	GND	4	Right Sound



Mitsumi CD (CN44)

Pin	Signal description	Pin	Signal description
1	GND	3	GND
2	Left Sound	4	Right Sound

- LAN Wakeup (CN5)



Pin	Signal description	Pin	Signal description
1	+5VSB	3	LANWK
2	GND		

- Modem Wakeup (CN51)



Pin	Signal description	Pin	Signal description
1	Modem Ring	3	+5VSB
2	GND		

- Indicator Header (CN48)

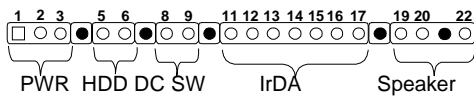

Pin	Signal description	Pin	Signal description
1	VCC	12	GND (Option)
2	PM indicator signal	13	IRTX (Option)
3	GND	14	VCC (Option)
4	Key	15	IRSEL (Option)
5	VCC	16	N.C
6	HDD access signal	17	GND (Option)
7	Key	18	Key (Option)
8	Power-ON switch signal	19	VCC (Option)
9	GND	20	GND (Option)
10	Key	21	N.C
11	IRRX (Option)	22	Speaker signal (Option)

- Aux. Indicator Header (CN49) (Option)

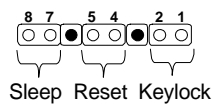

Pin	Signal description	Pin	Signal description
1	Key lock Signal to Super I/O	2	GND
3	Key	4	Reset signal
5	GND	6	Key
7	Sleep Function signal	8	GND

2-2. Motherboard External I/O Port

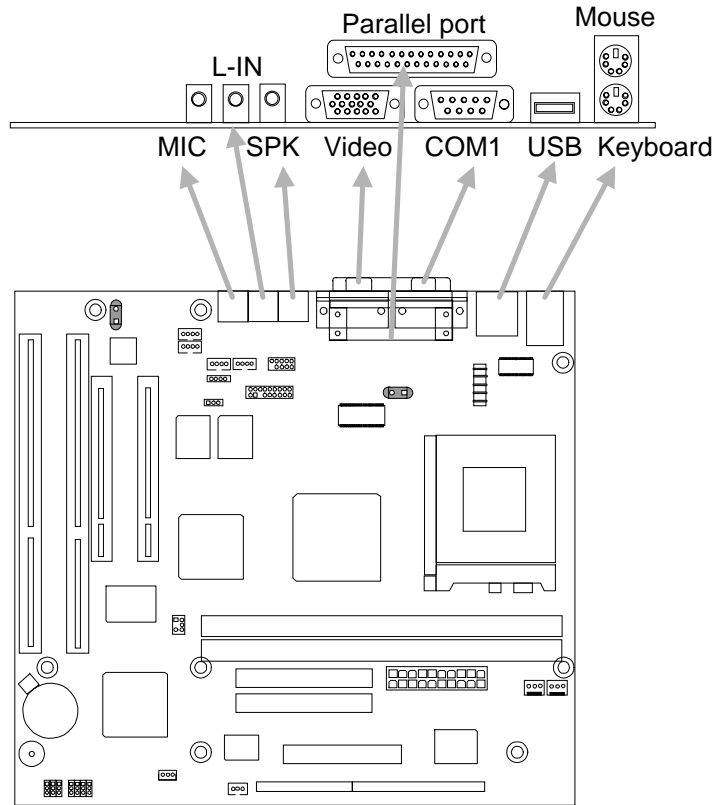

3. Joystick & USB daughter board

20pin Flat Cable

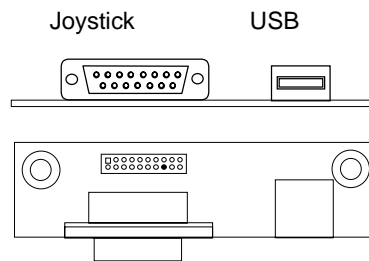

4. LED & Power S/W board

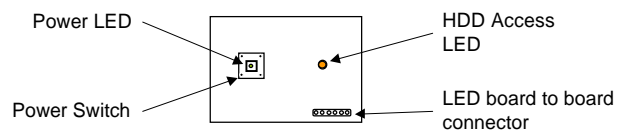

- Power LED color : Green (normal working)
Blinking Green (power management mode)
- HDD LED color : Green light on (HDD access)
Light off (no access to HDD device)